

2026

ALISEO



LUXURY  
HOSPITALITY  
SOLUTIONS





HIDDEN CHAMPION  
FROM THE BLACK FOREST



Seit 40 Jahren steht ALISEO für herausragende Designlösungen in der Hospitality-Welt. Verwurzelt im Schwarzwald, geprägt von deutscher Präzision und geführt in zweiter Generation, verbinden wir luxuriöse Ästhetik mit höchster Funktionalität. Als Hidden Champion setzen wir weltweit Maßstäbe in Qualität und Innovation. Unser Anspruch: Luxury Hospitality Solutions – Produkte, die nicht nur Räume bereichern, sondern Erlebnisse schaffen. Erleben Sie, wie Exzellenz, Verlässlichkeit und Designperfektion die Zukunft der Hospitality-Ausstattung definieren.

For 40 years, ALISEO has stood for outstanding design solutions in the hospitality world. Rooted in the Black Forest, characterized by German precision and managed by the second generation, we combine luxurious aesthetics with maximum functionality. As a hidden champion, we set global standards in quality and innovation. Our claim: Luxury Hospitality Solutions - products, which not only enrich rooms, but also create experiences. Experience how excellence, reliability and design perfection define the future of hospitality furnishings.

## FAMILY BUSINESS THE SECOND GENERATION







ALISEO

BYE BYE BORING  
BE INSPIRED

ALISEO

ALISEO

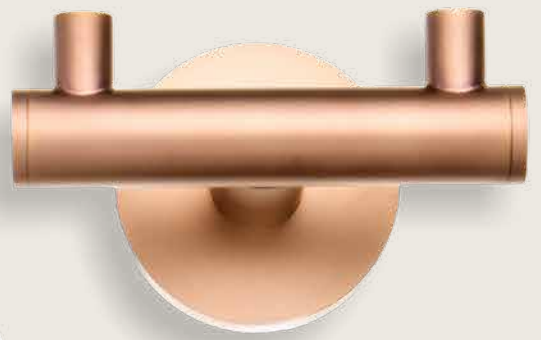

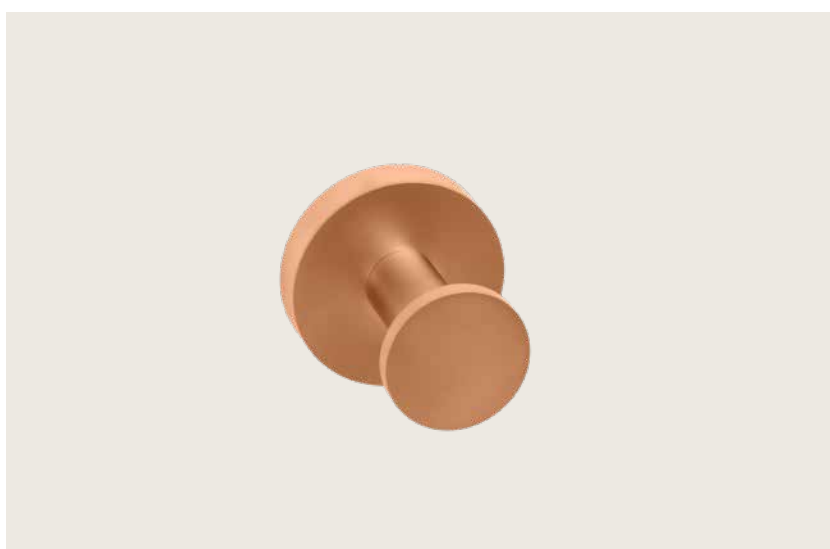



I N H A L T  
C O N T E N T

HAARTROCKNER. HAIR DRYERS	14-45
Vento Brushless	18-21
Aero Brushless	22-23
Chromosome	24-27
Carbonic	28-31
Black Mambo	32-35
Polarfox	36-39
Chromo	40-43
Pro	44-45
Haarglätter. Hair Straightener	46-47
Aurea Sleek & Curl	46
Aurea Sleek	47
KOSMETIKSPIEGEL. COSMETIC MIRRORS	52-85
LED Moon Dance	56-61
LED ME	62-65
LED MY	66-67
LED Saturn	68-69
LED Interface	70-73
LED City Light	74-75
Mira	76-77
Cosmo Minimalist	78-79
Face	80-83
Concierge Collection	84-85
Badezimmerspiegel. Bathroom Mirrors	86-89
Ore	88
Joy	89
HOTELBAD. HOTEL BATHROOM	90-143
Handtuchwärmer. Towel Heaters	92-99
Amber Pro	94-95
Pearl Pro	96-97
Rock	98-99
Accessoire-Serien. Accessory Lines	100-131
Architecto	104-107
Maxima	108-113
Tecno	114-117
Now	118-121
Nexus	122-125
Complementary	126-131
Hygieneeimer/Abfallbehälter. Waste Bins	132-139
Personenwaagen. Scales	140-143
GÄSTEZIMMER. GUESTROOM	144-194
Londoner Leder-Accessoires. Leather Accessories	146-167
Wasserkocher. Water Kettles	168-174
Tabletts. Trays	175-177
Kofferablagen. Luggage Racks	178-181
Bügeln. Ironing	182-194



# AM ANFANG STEHT DIE VISION IT ALL STARTS WITH A VISION



Individuelle Farben und Oberflächen ermöglichen die perfekte Umsetzung Ihrer Vision. Denn es sind Details wie diese, die den Unterschied machen. Wir haben mit ALISEO ATELIER einen Bereich geschaffen, in dem wir grenzenlose Farbvielfalt ermöglichen.

Stöbern Sie im ATELIER Katalog oder entdecken Sie noch mehr Inspiration online.

Individual colors and surfaces enable the perfect implementation of your vision. Because it's details like these that make the difference. With ALISEO ATELIER, we have created an area in which we enable limitless color variety.

Have a look through the ATELIER catalog or discover even more inspiration online.



Unsere Clutch ist standardmäßig in elegantem Schwarz erhältlich. Weitere attraktive Farbvarianten finden Sie auf Seite 163.

Our clutch is available in an elegant standard black. Discover additional attractive color options on page 163.

Als besonderes optisches Highlight präsentiert sich der Vento im BYE BYE BORING Concept. Mit thermoplastischer Oberflächenveredelung lässt er sich in jede Wunschfarbe verwandeln und passt sich so mühelos jedem Stil- und Farbkonzept an.

Stilvoll verstaut in einer farblich perfekt abgestimmten Clutch aus feinem Kunstleder wird das Konzept zum absoluten Must-have. Ein Accessoire, das Design und Funktion vereint und garantiert für Wow-Momente sorgt.

As a striking visual highlight, VENTO is available in the exclusive BYE BYE BORING Concept. With thermoplastic surface finishing, it can be transformed into any desired color, seamlessly blending into any style or interior concept.

Elegantly stored in a color-coordinated clutch made of fine faux leather, this concept becomes an absolute must-have. An accessory that unites design and function, guaranteed to create wow moments.



H A A R T R O C K N E R  
H A I R D R Y E R



BLOW



IONTECH

Die Ionen-Trocknungstechnologie bei Haartrocknern nutzt negative Ionen, um die positiven Ionen im Wasser zu neutralisieren und die Feuchtigkeit schneller aus dem Haar zu entfernen. Dies führt zu einer schonenderen und effizienteren Trocknung, die das Haar glatter, glänzender und gesünder erscheinen lässt, während Frizz und statische Aufladung reduziert werden. Haartrockner mit dieser Technologie sind beliebt, da sie Haarschäden minimieren und die Haarstruktur bewahren. Ionic drying technology in hair dryers uses negative ions to neutralize the positive ions in the water and remove moisture from the hair faster. This results in gentle and more efficient drying, leaving hair smoother, shinier and healthier, while reducing frizz and static. Hair dryers with this technology are popular because they minimize hair damage and preserve the hair structure.



plug in  
EU-CH-UK

Ohne Halterung. Mit Stecker zum Anschluss an Steckdose

Without holder. With plug for plug-in application



HANG-UP

Einfaches Einhängen. Integrierter Silikonring verhindert Kratzer

Easy Drop-In Design. Rubber insert guards against scratches and wear and tear



DROP-IN

Praktische Designhalterung DROP-IN mit Kratzschutz und beleuchtetem Netztrennschalter für zusätzliche Sicherheit.

Convenient drop-in holder with rubber snug-fit insert to protect against scratches and wear and tear. Illuminated interrupter switch guards against circuit leakage.

Unsere Haartrockner sind auf Anfrage mit zusätzlichem Kabel und Stecker zum Anschluss an die Steckdose erhältlich

Our hair dryers are available with additional cord and plug for plug-in application on request.



ALISEO

ALISEO

200

100



STRONG. SMALL. SILENT.

## VENTO BRUSHLESS

Der neue Hotelhaartrockner VENTO setzt neue Maßstäbe in Sachen Leistung, Langlebigkeit und Pflege. Sein Herzstück ist ein hochmoderner bürstenloser Motor (Brushless DC Motor), der speziell für die Anforderungen der Hotellerie adaptiert wurde.

The new VENTO hotel hair dryer sets new standards in terms of performance, durability and care. At its heart is an ultra-modern brushless DC motor, which has been specially adapted to the requirements of the hotel industry.

Bürstenloser DC-Hochleistungsmotor  
ohne Verschleiß

Wellness-Ionen-Technologie

Temperaturwahl über 3 Schaltstufen

inkl. Kaltluftfunktion

Zwei Gebläsestufen

Abnehmbare Düse

Überhitzungsschutz

Doppelte Isolierung

Schutzklasse II

Glattes Kabel, 180 cm

Energiesparer: Hocheffizient mit nur 1400 W

Brushless high performance

DC motor without wear

Wellness ionic technology

Three temperature settings

with cold air function

Two air speeds

Removable nozzle

Overheating protection

Double insulation

Class II

Straight cord, 180 cm

Energy saver: highly efficient with only 1400 W

230 V, 50 Hz, Cool/700/1400 W



high speed  
brushless motor



low noise



lightweight



small



Wellness  
IONTECH



drawer solution



plug in  
EU-CH-UK



HANG-UP

Mikrofilter verhindert das Eindringen von Staub und ermöglicht eine einfache Reinigung

Micro Filter to prevent dust from entering and for easy cleaning

Drei Temperatureinstellungen mit Kaltluftfunktion

Three temperature settings with cold air function



Rot/Orange/Blau  
3-Farben-LED  
Wärmeanzeigen

Red/Orange/Blue  
3-Color LED  
heat indications



Zwei Gebläsestufen

Two air speeds

Abnehmbare Filterabdeckung für den Lufteinlass zur einfachen Reinigung

Detachable air inlet filter cover for easy cleaning

## HIGH-TECH. AT. HEART.

Der bürstenlose Motor ist das Herzstück dieses Luxus-Haartrockners – leistungsstark, effizient und praktisch wartungsfrei. Er läuft besonders leise, spart Energie und überzeugt mit einer beeindruckenden Lebensdauer. Ideal für den anspruchsvollen Dauereinsatz im Hotel – smart, zuverlässig und bereit für das nächste Level.

The brushless motor is the heart of this luxury hair dryer – powerful, efficient and practically maintenance-free. It runs particularly quietly, saves energy and boasts an impressive service life. Ideal for demanding continuous use in hotels – smart, reliable and ready for the next level.



- 1 Abnehmbare magnetische Formdüse  
Removable magnetic nozzle
- 2 Micro-Sieb gegen Eindringen von Staub und für einfache Reinigung  
Micro sieve to prevent dust from entering and for easy cleaning
- 3 Mehrere Schaltstufen & Kaltluftfunktion  
Variable speed & cold shot function

- 4 Sehr kleines und ultra-leichtes Kraftpaket: kleiner und leichter als alle ähnlichen Modelle auf dem Markt  
Very small and ultra light power pack: smaller and lighter than all similar models on the market

Ohne Halterung. Mit Aufbewahrungstasche und Gummikabelbinder  
Glattes Kabel und Stecker zum Anschluss an Steckdose  
Without holder. With storage bag and rubber cable tie  
With plug for plug-in application

# 010643 dunkelgrau metallic  
darkgrey metallic

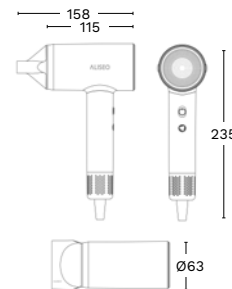

drawer solution



plug in  
EU-CH-UK



010643

NEW

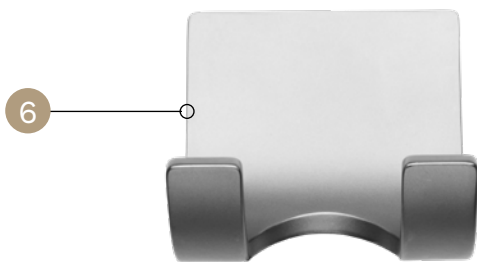

- 5 Wandhalterung HANG-UP für einfaches Einhängen  
Wall holder HANG-UP
- 6 Mit Netztrennschalter  
With interrupter switch

Wandhalterung mit Netztrennschalter  
Direktanschluss  
Wall holder with interrupter switch  
Hard wired application

# 010651 dunkelgrau metallic  
darkgrey metallic

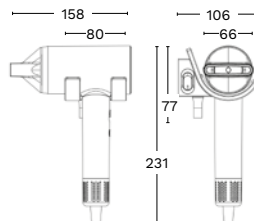

HANG-UP



010651



NEW

STRONG. EXTRA SMALL. SILENT.  
**AERO BRUSHLESS**

Der AERO BRUSHLESS ist der neueste Zuwachs unserer leistungsstarken Brushless-Familie. Kompakter, leichter und noch ergonomischer als sein großer Bruder, der VENTO. Trotz seiner deutlich handlicheren Bauweise überzeugt der AERO BRUSHLESS mit beeindruckender Performance, sodass er perfekt für den anspruchsvollen Hotelalltag geeignet ist.

The AERO BRUSHLESS is the latest addition to our powerful brushless family. It is more compact, lighter, and even more ergonomic than its big brother, the VENTO. Despite its significantly more handy design, the AERO BRUSHLESS impresses with its outstanding performance, making it perfect for demanding everyday use in hotels.

- |                                       |                                  |
|---------------------------------------|----------------------------------|
| Temperatúrauswahl über 3 Schaltstufen | Three temperature settings       |
| Zwei Gebläsestufen                    | Two air speeds                   |
| Bürstenloser DC-Motor                 | Brushless DC motor               |
| Abnehmbare Düse                       | Removable nozzle                 |
| Überhitzungsschutz                    | Overheating protection           |
| Doppelte Isolierung                   | Double insulation                |
| Schutzklasse II                       | Class II                         |
| Spiralkabel, 50-120 cm (# 010659)     | Coil cord, 50-120 cm (# 010659)  |
| Glattes Kabel, 200 cm (# 010656)      | Straight cord, 200 cm (# 010656) |

220-240 V, 50/60 Hz, Cool /600/1200 W



- high speed  
brushless motor
- low noise
- lightweight
- extra small
- drawer solution
- plug in  
EU-CH-UK
- HANG-UP

- 1 3-Farben-LED Wärmeanzeige  
3-Color-LED heat indications  

- 2 Abnehmbare Filterabdeckung für den Lufteinlass  
zur einfachen Reinigung  
Detachable air inlet filter cover for easy cleaning
- 3 Mehrere Schaltstufen & Kaltluftfunktion  
Variable speed & cold shot function

Ohne Halterung. Mit Aufbewahrungstasche und Klett-Kabelbinder.  
Glattes Kabel und Stecker zum Anschluss an Steckdose  
Without holder. With storage bag and velcro cable tie  
With plug for plug-in application

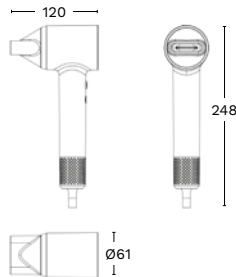
# 010656 dunkelgrau metallic  
darkgrey metallic



- 4 Wandhalterung HANG-UP  
für einfaches Einhängen  
Wall holder HANG-UP
- 5 Abnehmbare Düse  
Removable nozzle

Wandhalterung mit Netztrennschalter  
Direktanschluss  
Wall holder with interrupter switch  
Hard wired application

# 010659 dunkelgrau metallic  
darkgrey metallic

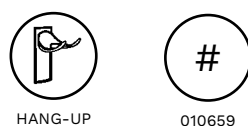
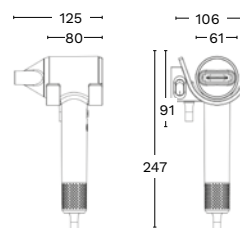



BLOWN. AWAY.

## CHROMOSOME

Vor 40 Jahren revolutionierte ALISEO die Hotellerie mit dem weltweit ersten Hotelhaartrockner – eine Innovation, die seither tief in der DNA unserer Marke verankert ist. Mit CHROMOSOME schreiben wir 2025 diese Erfolgsgeschichte fort: ein kraftvolles Design, das sich bewusst vom Gewohnten abhebt und frischen Wind ins Hotelbad bringt.

Das Beste daran? Ein unschlagbares Preis-Leistungs-Verhältnis macht CHROMOSOME zum neuen Aushängeschild unseres Einstiegspreissegments – natürlich in der bewährten ALISEO-Qualität.

40 years ago, ALISEO revolutionized the hotel industry with the world's first hotel dryer - an innovation that has been deeply rooted in the DNA of our brand ever since. With CHROMOSOME, we are continuing this success story in 2025: a powerful design that deliberately sets itself apart from the familiar and brings a breath of fresh air to the hotel bathroom.

The best thing about it? An unbeatable price-performance ratio makes CHROMOSOME the new flagship of our entry-level price segment - in proven ALISEO quality, of course.

Temperatúrauswahl über 3 Schaltstufen

Zwei Gebläsestufen

Kaltlufttaste

DC-Motor

Abnehmbare Düse

Überhitzungsschutz

Doppelte Isolierung

Schutzklasse II

Spiralkabel, 50-120 cm (# 010634)

Glattes Kabel, 180 cm (# 010633)

Three temperature settings

Two air speeds

Cold shot button

DC motor

Removable nozzle

Overheating protection

Double insulation

Class II

Coil cord, 50-120 cm (# 010634)

Straight cord, 180 cm (# 010633)

220-240 V, 50/60 Hz, Cool/900/1800 W



drawer solution



plug in  
EU-CH-UK



HANG-UP





- 1 Kraftvolles Design mit leistungsstarkem 1800 Watt DC Motor  
Powerful Design with high-performance 1800 watt DC motor
- 2 Mehrere Schaltstufen & Kaltlufttaste  
Variable speed & cold shot controls

Ohne Halterung. Mit Aufbewahrungstasche und Klett-Kabelbinder  
 Glattes Kabel und Stecker zum Anschluss an Steckdose  
 Without holder. With storage bag and velcro cable tie  
 With plug for plug-in application

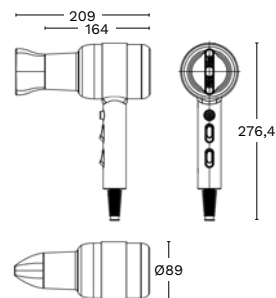
# 010633 dunkelgrau metallic  
 darkgrey metallic



		
drawer solution	plug in EU-CH-UK	010633





- 3 Abnehmbare Formdüse  
Removable nozzle
- 4 Wandhalterung HANG-UP  
für einfaches Einhängen  
Wall holder HANG-UP

Wandhalterung mit Netztrennschalter  
Direktanschluss  
Wall holder with interrupter switch  
Hard wired application

# 010634 dunkelgrau metallic  
darkgrey metallic

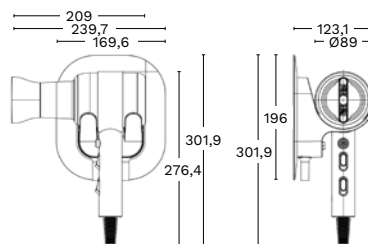

HANG-UP



010634

# CARBONIC



ELEGANT. EFFECTIVE.

## CARBONIC

CARBONIC 1900 kommt mit futuristisch anmutender Oberfläche und auch im inneren mit technischer Perfektion. Der effektive AC-Motor bringt das Quäntchen mehr Leistung, wenn es darauf ankommt. Schonende ION-TECH-Technologie inbegriffen.

CARBONIC 1900 comes with a futuristic-looking surface and technical perfection on the inside too. The effective AC motor delivers that little bit more power when it counts. Gentle ION-TECH technology included.

Ionen-Technologie  
Drei Temperaturstufen  
Zwei Gebläsestufen  
Kaltlufttaste  
AC-Motor  
Abnehmbare Düse  
Überhitzungsschutz  
Doppelte Isolierung  
Schutzklasse II  
Spiralkabel, 60 cm

Ionic technology  
Three heat settings  
Two air speeds  
Cold shot button  
AC motor  
Removable nozzle  
Overheating protection  
Double insulation  
Class II  
Coil cord, 60 cm

220-240 V, 50/60 Hz, Cool/950/1900 W



IONTECH



carbon pattern



drawer solution



plug in  
EU-CH-UK



HANG-UP



DROP-IN



- 1 Ausführung in Karbonoptik  
High gloss Carbonic Optic
- 2 Mehrere Schaltstufen & Kaltlufttaste  
Variable speed & cold shot controls

Ohne Halterung. Mit Aufbewahrungstasche  
Mit Stecker zum Anschluss an Steckdose  
Without holder. With storage bag  
With plug for plug-in application

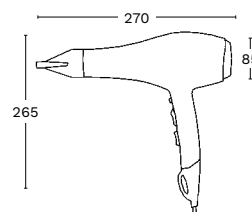

# 010493

Karbon-Muster  
carbon-pattern



drawer solution



plug in  
EU-CH-UK



010493

# CARBONIC



- 3 Einfaches Einhängen. Integrierte Gelpads verhindern Kratzer  
Hang-up cradle design with gel pad protection
- 4 Austauschbarer Haarfilter  
Removable E-Z Care Hair Filter

Wandhalterung HANG-UP mit Netztrennschalter  
Direktanschluss  
Wall holder HANG-UP with interrupter switch  
Hard wired application

# 010502

Karbon-Muster  
carbon-pattern

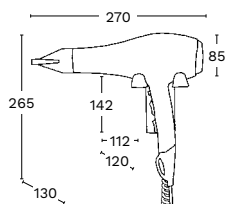

HANG-UP



010502



- 5 Einfaches Einhängen  
Easy Drop-In Design
- 6 Integrierter Silikonring verhindert Kratzer  
Rubber insert guards against scratches and wear and tear

Wandhalterung DROP-IN mit Netztrennschalter  
Direktanschluss  
Wall holder DROP-IN with interrupter switch  
Hard wired application

# 010543

Karbon-Muster  
carbon-pattern

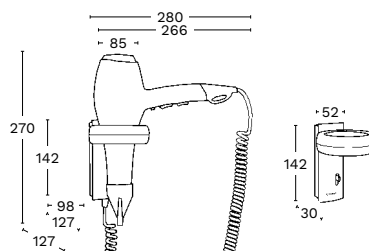

DROP-IN



010543

# POWER



ELEGANT. EFFECTIVE.

## BLACK MAMBO

ALISEO's Powerpaket unter den Hotel-Haartrocknern ist keine Black Mamba, sondern BLACK MAMBO. Aber mindestens genauso elegant und effektiv. Die matte Soft-Touch-Oberfläche macht ihn zum seidigen Killer für nasses Haar und ist dank ION-TECH doch super schonend.

ALISEO's power pack among hotel hair dryers is not a Black Mamba, but BLACK MAMBO. But at least as elegant and effective. The matt soft-touch surface makes it a silky killer for wet hair and is super gentle thanks to ION-TECH.

Ionen-Technologie  
Drei Temperaturstufen  
Zwei Gebläsestufen  
Kaltlufttaste  
AC-Motor  
Abnehmbare Düse  
Überhitzungsschutz  
Doppelte Isolierung  
Schutzklasse II  
Spiralkabel, 60 cm

Ionic technology  
Three heat settings  
Two air speeds  
Cold shot button  
AC motor  
Removable nozzle  
Overheating protection  
Double insulation  
Class II  
Coil cord, 60 cm

220-240 V, 50/60 Hz, Cool/900/1875 W



IONTECH



matt soft-touch  
surface



drawer solution



plug in  
EU-CH-UK



HANG-UP



DROP-IN



- 1 Soft-Touch-Komfortbeschichtung für angenehme Handhabung  
Soft-touch comfort coating with anti-slip protection.
- 2 Mehrere Schaltstufen & Kaltlufttaste  
Variable speed & cold shot controls

Ohne Halterung. Mit Aufbewahrungstasche  
Mit Stecker zum Anschluss an Steckdose  
Without holder. With storage bag  
With plug for plug-in application

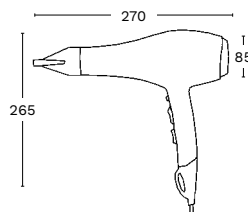

# 010492 schwarz, Soft-Touch  
black, soft-touch



drawer solution



plug in  
EU-CH-UK



010492

# BLACK MAMBO



**3** Einfaches Einhängen. Integrierte Gelpads verhindern Kratzer  
Hang-up cradle design with gel pad protection

**4** Langlebiger 1875 Watt AC-Motor  
1875 Watt long-life AC-motor

Wandhalterung HANG-UP mit Netztrennschalter  
Direktanschluss  
Wall holder HANG-UP with interrupter switch  
Hard wired application

# 010596

schwarz/Easy-Touch  
black/EZ touch

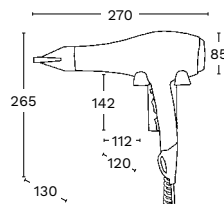

HANG-UP



010596



- 5 Einfaches Einhängen  
Easy Drop-In Design
- 6 Integrierter Silikonring verhindert Kratzer  
Rubber insert guards against scratches and wear and tear

Wandhalterung DROP-IN mit Netztrennschalter  
Direktanschluss  
Wall holder DROP-IN with interrupter switch  
Hard wired application

# 010598

schwarz/Easy-Touch  
black/EZ touch

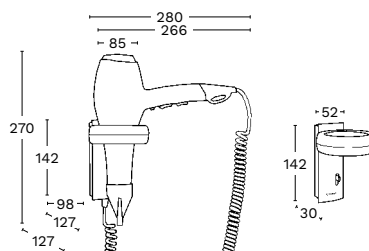

DROP-IN



010598



ELEGANT. EFFECTIVE.

## POLARFOX

Reine Eleganz und volle Power. ALISEO's POLARFOX 1875 ist dank weißer Hochglanzoptik geradezu majestätisch stilvoll, steht aber Black Mambo und Carbonic in Sachen Power in nichts nach. Dank ION-TECH wird das Haar beim Trocknen auch geschützt.

Pure elegance and full power. ALISEO's POLARFOX 1875 is downright majestically stylish thanks to its white high-gloss finish, but is in no way inferior to Black Mambo and Carbonic in terms of power. Thanks to ION-TECH, the hair is also protected when drying.

Ionen-Technologie  
 Drei Temperaturstufen  
 Zwei Gebläsestufen  
 Kaltlufttaste  
 AC-Motor  
 Abnehmbare Düse  
 Überhitzungsschutz  
 Doppelte Isolierung  
 Schutzklasse II  
 Spiralkabel, 60 cm

Ionic technology  
 Three heat settings  
 Two air speeds  
 Cold shot button  
 AC motor  
 Removable nozzle  
 Overheating protection  
 Double insulation  
 Class II  
 Coil cord, 60 cm

220-240 V, 50/60 Hz, Cool/900/1875 W



IONTECH



drawer solution



plug in  
EU-CH-UK



HANG-UP



DROP-IN



- 1** Langlebiger 1875 Watt AC-Motor  
1875 Watt long-life AC-motor
- 2** Mehrere Schaltstufen und  
Kaltlufttaste  
Variable speed and cold shot controls

Ohne Halterung. Mit Aufbewahrungstasche  
Mit Stecker zum Anschluss an Steckdose  
Without holder. With storage bag  
With plug for plug-in application

# 010547

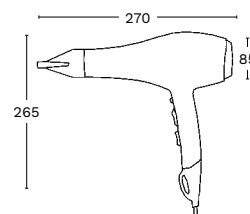
weiß/silber  
white/silver

drawer solution

plug in  
EU-CH-UK

010547



- 3 Einfaches Einhängen  
Easy Hang-up cradle design
- 4 Langlebiger 1875 Watt AC-Motor  
1875 Watt long-life AC-motor

Wandhalterung HANG-UP mit Netztrennschalter  
Direktanschluss  
Wall holder HANG-UP with interrupter switch  
Hard wired application

# 010548    weiß/silber  
white/silver

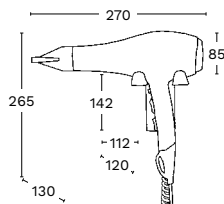

HANG-UP



010548



- 5 Einfaches Einhängen  
 Integrierter Silikonring verhindert Kratzer  
 Easy Drop-In Design  
 Rubber insert guards against scratches  
 and wear and tear

Wandhalterung DROP-IN mit Netztrennschalter  
 Direktanschluss  
 Wall holder DROP-IN with interrupter switch  
 Hard wired application

# 010549

weiß/silber  
 white/silver

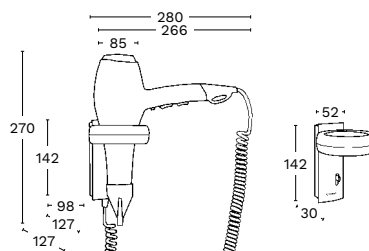

DROP-IN



010549

# RETRO



SAFE. RETRO LOOK.

## CHROMO

Nicht umsonst eines unserer meistverkauften Modelle. CHROMO kommt mit einem unwiderstehlichen Retro-Look und dem Plus an Sicherheit. Als klassischer Hotelhaartrockner wird er über einen Tastschalter betrieben, der die Stromzufuhr unterbricht, sobald er nicht mehr gedrückt wird. Sicherer geht es nicht.

One of our best-selling models for a reason. CHROMO comes with an irresistible retro look and the added bonus of safety. As a classic hotel hair dryer, it is operated via a push-button that interrupts the power supply as soon as it is no longer pressed. It couldn't be safer.

Soft-Touch Gehäuse  
DC-Motor  
2 Schaltstufen  
Sicherheits-Tastschalter  
Abnehmbare Düse  
Überhitzungsschutz  
Doppelte Isolierung  
Schutzklasse II  
Spiralkabel, 50 cm

Soft-touch housing  
DC-Motor  
2 output steps  
Hotel safety switch  
Removable nozzle  
Overheating protection  
Double insulation  
Class II  
Coil cord, 50 cm

220-240 V, 50/60 Hz, 600/1200 W



matt soft-touch  
surface



drawer solution



plug in  
EU-CH-UK



ring holder



wall holder



- 1 Mit schmaler Düse für exaktes Styling  
Narrow air concentrator for pinpoint styling
- 2 Soft-Touch Komfortbeschichtung  
in schwarz mattem Finish  
Soft-touch Comfort Coating in a  
distinctive matt black finish
- 3 Mehrere Schaltstufen  
Variable speed
- 4 Komfortabler, rutschfester Handgriff  
Comfortable ribbed anti-slip handle

Ohne Halterung  
Mit Stecker zum Anschluss an Steckdose  
Without holder.  
With plug for plug-in application

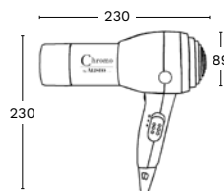

# 010437 chrom/schwarz  
chrome/black

 drawer solution	 plug in EU-CH-UK	 # 010437
--	--	--



- 5 Wandhalterung, Messing, verchromt  
Montage mit Diebstahlschutz  
Wall holder, brass, chrome plated  
Wire-thru anti-theft protection

Mit Ringhalterung.  
Spiralkabel mit Stecker.  
With ring holder.  
Coil cord with plug.

# 010330

chrom/schwarz  
chrome/black

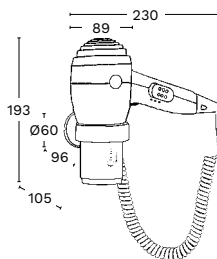

ring holder



010330



- 6 Netztrennschalter  
Safety security switch
- 7 Gummierter Innenring zum Schutz  
Rubber inner-ring scratch protection
- 8 Design-Halterung mit Kratzschutz  
Low profile holder

Wandhalterung mit Netztrennschalter.  
Direktanschluss.  
Wall holder with interrupter switch.  
Hard wired.

# 010407

chrom/schwarz  
chrome/black

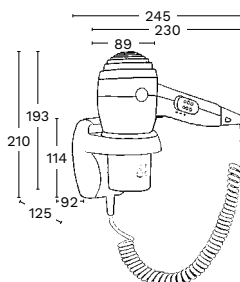

wall holder



010407

O

R

G

I

N

A

L



SUSTAINABLE. ECONOMICAL. EFFICIENT.

## PRO

Mehr als 500.000 Installationen auf 6 Kontinenten haben seinen legendären Ruf begründet.  
A 20 year track record with over 500,000 installations on 6 continents

Hotel-Sicherheits-Tastschalter  
1 Schaltstufe  
Überhitzungsschutz  
Doppelte Isolierung  
Schutzklasse II  
Spiralkabel, 40 cm

Hotel safety switch  
1 output step  
Overheating protection  
Double insulation  
Class II  
Coil cord, 40 cm

220-250 V, 50/60 Hz, 1200 W



DROP-IN

PRO  
The Original



Wandhalterung mit Netztrennschalter  
Direktanschluss  
Wall holder with interrupter switch  
Hard wired application

# 010001

weiß/schwarz  
white/black

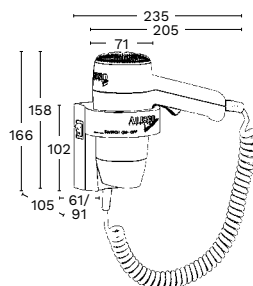

010001



NEW



**AUREA SLEEK & CURL**

- Haarglätter
- Eingebauter Überhitzungsschutz
- PTC-Heizelement und Ionen-Technologie
- Floating-Plate Technologie:
- Digitale LED-Temperaturregelung: 150-230 °C
- 360° drehbares Kabel
- Inklusive Tasche zur Aufbewahrung
- Keramikbeschichtete Platten
- Automatische Abschaltfunktion nach 15 Minuten
- Doppelt isoliert (Schutzklasse II)

- Hair Straightener
- Integrated overheating protection
- PTC heater and ionic technology
- Floating-plate technology
- Digital LED temperature control: 150-230 °C
- 360 ° swivel cord
- Including bag for storage
- Ceramic coating plates
- Auto-shut-off function within 15 minutes
- Double insulated (Class II)

110-240 V, 50/60 Hz, 52 W



010649



drawer solution



auto-shut-off



sleek & curl

# 010649 schwarz matt/gold  
black matt/gold

BEAUTY IN. SLEEK & CURL.

# HAARGLÄTTER. HAIR STRAIGHTENER

Erlebe die Kunst des Glättens neu – mit AUREA SLEEK. Das Stylingtool, das Präzision, Eleganz und Pflege vereint. Mit Hilfe der Floating-Plate Technologie gleitet der Haarglätter mühelos über jede Strähne, während sich die beweglichen Platten perfekt an das Haar anpassen. Das Ergebnis: seidig-glattes Haar in nur einem Zug. Wer sich nicht zwischen makellos glattem Haar und sanft definierten Locken entscheiden möchte, hat mit AUREA SLEEK & CURL beide Möglichkeiten. Ein Must-have in der Schublade jedes Hotelbades.

Discover the art of new styling - with AUREA SLEEK. The styling tool that combines precision, elegance, and care. With the help of floating plate technology, the hair straightener glides effortlessly over every strand, while the movable plates adapt perfectly to the hair. The result: silky-smooth hair in just one move. If you don't want to choose between flawlessly straight hair and softly defined curls, AUREA SLEEK & CURL gives you both options. A must-have in every hotel bathroom drawer.



## AUREA SLEEK

Haarglätter

Eingebauter Überhitzungsschutz

PTC-Heizelement und Ionen-Technologie

Floating-Plate Technologie

Digitale LED-Temperaturregelung: 150-230 °C

360° drehbares Kabel

Inklusive Tasche zur Aufbewahrung

Keramikbeschichtete Platten

Automatische Abschaltfunktion nach 15 Minuten

Doppelt isoliert (Schutzklasse II)

Hair Straightener

Integrated overheating protection

PTC heater and ionic technology

Floating-plate technology

Digital LED temperature control: 150-230 °C

360 ° swivel cord

Including bag for storage

Ceramic coating plates

Auto-shut-off function within 15 minutes

Double insulated (Class II)

110-240 V, 50/60 Hz, 72 W



010648



drawer solution



auto-shut-off



sleek

# 010648

schwarz matt/gold  
black matt/gold



NU finishes

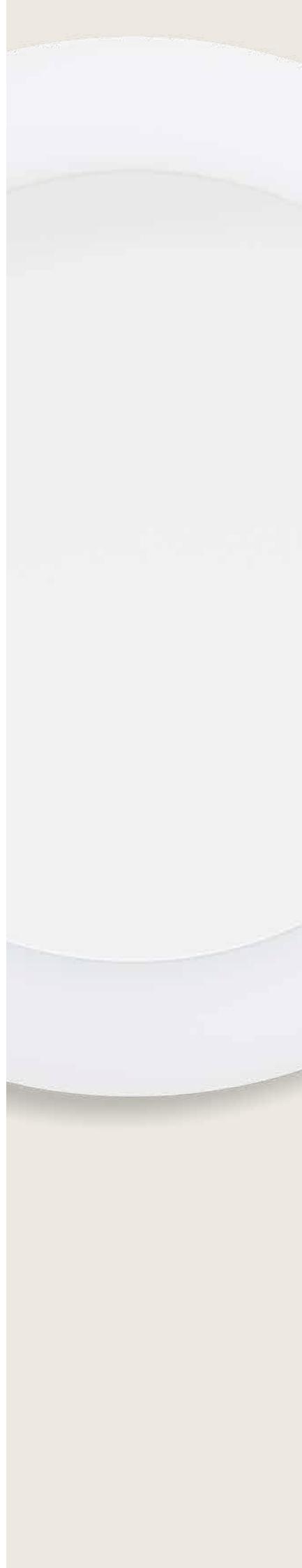

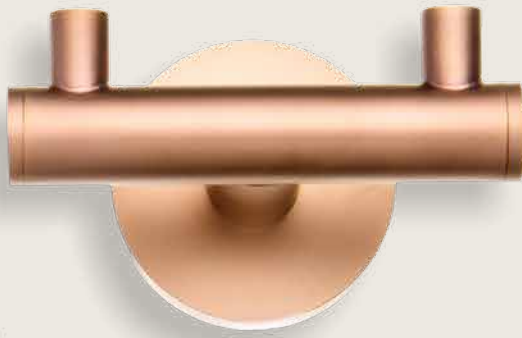

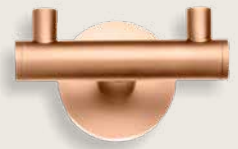

# AM ANFANG STEHT DIE VISION IT ALL STARTS WITH A VISION



Individuelle Farben und Oberflächen ermöglichen die perfekte Umsetzung Ihrer Vision. Denn es sind Details wie diese, die den Unterschied machen. Wir haben mit ALISEO ATELIER einen Bereich geschaffen, in dem wir grenzenlose Farbvielfalt ermöglichen.

Stöbern Sie im ATELIER Katalog oder entdecken Sie noch mehr Inspiration online.

Individual colors and surfaces enable the perfect implementation of your vision. Because it's details like these that make the difference. With ALISEO ATELIER, we have created an area in which we enable limitless color variety.

Have a look through the ATELIER catalog or discover even more inspiration online.

## GRENZENLOSE FARBAUSWAHL UNLIMITED CHOICE OF COLORS

Der Kreativität sind keine Grenzen gesetzt: Im PVD-Verfahren lassen sich nahezu alle Farben realisieren. Als Basis genügt ein Muster oder der Farbcode des Herstellers. Zur Vereinfachung haben wir die beliebtesten metallischen Farben – jeweils poliert oder gebürstet – übersichtlich zusammengestellt und uns dabei an gängigen Oberflächen namhafter Sanitärhersteller orientiert. Perfect Match eben.

There are no limits to creativity: Nearly any color can be achieved with the PVD process. A sample or the manufacturer's color code is all we need. To make things easier, we have compiled the most popular metallic colors—each available in polished or brushed finishes—in a clear overview, taking inspiration from the common surface tones of renowned sanitary manufacturers. A perfect match.

### POLIERT. POLISHED

CHROM 100  
CHROME 100



CHROM 302  
CHROME 302

BRONZE 201



BRONZE 301

GOLDOPTIK 203  
GOLD OPTIC 203



GOLDOPTIK 303  
GOLD OPTIC 303

MESSING 206  
BRASS 206



MESSING 306  
BRASS 306

NICKEL 207



NICKEL307

ROTGOLD 209  
RED GOLD 209



ROTGOLD 309  
RED GOLD 309

CHROM SCHWARZ 211  
BLACK CHROME 211



CHROM SCHWARZ 311  
BLACK CHROME 311

### GEBÜRSTET. BRUSHED



Alle Artikel, bei denen das Symbol der NU finishes zu finden ist, kann mit Wunschoberfläche gestaltet werden.

All items with the NU finishes symbol can be designed with the individual finish of your choice.



Unsere Oberflächen in Sonderfarbe entstehen durch PVD-Beschichtung. Egal ob Hochglanz, gebürstet oder matt, die Vorteile sind klar: Sie ist langlebig, kratzfest und trotz Feuchtigkeit. Und weil wir von der Qualität überzeugt sind, gewähren wir eine freiwillige Garantie von 5 Jahren. Bitte beachten Sie unsere Montage- und Pflegehinweise.

Our surfaces in special colors are created by PVD coating. Whether high polish, brushed or matt, the advantages are clear: it is durable, scratch-resistant and withstands moisture. And because we are convinced of the quality, we offer a voluntary 5-year guarantee. Please note our installation and care instructions.



KOSMETIKSPIEGEL  
COSMETIC MIRRORS





Die T3-Technologie macht Lichtsteuerung intuitiv: Ein Touch genügt, um zwischen warmweißem Licht, kaltweißem Licht und Aus zu wechseln. So lässt sich die Beleuchtung individuell anpassen – je nach Tageszeit, Umgebung oder Vorliebe. Ein komfortables Extra, das Gästen spürbar mehr Kontrolle und Wohlbefinden schenkt. (Standardausführung bei den Kosmetikspiegeln SATURN, CUBIK und MOON DANCE.)

Revolutionary T<sup>3</sup> lighting makes light control intuitive: one touch is all it takes to switch between warm white light, cool white light and off. This allows the lighting to be individually adjusted - depending on the time of day, surroundings or preference. A convenient extra that gives guests noticeably more control and well-being. (Standard on SATURN, CUBIK and MOON DANCE mirrors.)



magnification

Unsere Kosmetikspiegel mit 3-fach-Vergrößerung bieten die perfekte Balance zwischen Übersicht und Genauigkeit und sorgen für ein komfortables, natürliches Spiegelbild. Dank dieser Vergrößerungsstufe behalten Sie das gesamte Gesicht im Blick – für ein rundum angenehmes Nutzungserlebnis.

Our cosmetic mirrors with 3x magnification offer the perfect balance between overview and accuracy, ensuring a comfortable, natural reflection. Thanks to this magnification level, you can see your entire face at a glance – for an all-round pleasant user experience.



magnification

Unsere Kosmetikspiegel mit 5-fach-Vergrößerung ermöglichen eine besonders detailgenaue Ansicht – selbst feinste Nuancen werden sichtbar. In Kombination mit unseren hochwertigen Spiegelflächen bietet die 5-fach-Vergrößerung ein luxuriöses Pflegeerlebnis – für Perfektion, die man sieht.

Our cosmetic mirrors with 5x magnification provide a particularly detailed view—even the finest nuances become visible. In combination with our high-quality mirror surfaces, the 5x magnification offers a luxurious skincare experience—for perfection you can see.



green efficiency

Unsere Kosmetikspiegel mit wartungsfreier LED-Beleuchtung kombinieren Energieeffizienz mit langer Lebensdauer. Die LEDs sind einzeln geschaltet – fällt mal eine aus, leuchten die anderen zuverlässig weiter. Und das Beste: Die Beleuchtung ist als Ersatzteil erhältlich und einfach austauschbar. Für nachhaltigen Komfort und dauerhaft strahlende Gästelerlebnisse.

Our vanity mirrors with maintenance-free LED lighting combine energy efficiency with a long service life. The LEDs are individually switched - if one fails, the others continue to light up reliably. And best of all, the lighting is available as a spare part and is easy to replace. For lasting comfort and a long-lasting, radiant guest experience.



ambient light

Spiegel mit transluzenter Rückseite erzeugen ein sanftes, indirektes Licht – perfekt für eine elegante Ambientebeleuchtung. Das Licht fällt nicht nur nach vorn, sondern auch dezent nach hinten und taucht den Raum in eine stimmungsvolle Atmosphäre. Ein stilvolles Extra, das jedes Bad aufwertet.

Mirrors with translucent backs create a soft, indirect light - perfect for elegant ambient lighting. The light not only falls to the front, but also discreetly to the rear, bathing the room in an atmospheric ambience. A stylish extra that enhances any bathroom.



Mit den NU finishes gestalten Sie alle Kosmetikspiegel und Badaccessoires in Ihrer Wunschoberfläche und -farbe. Wir setzen diese dann als hochwertige PVD-Beschichtung um. Brillant, langlebig, kratz- und korrosionsbeständig und einfach zu reinigen.

With NU finishes, you can customize all cosmetic mirrors and bathroom accessories in the surface and color of your choice. We then apply these as a high-quality PVD coating. Brilliant, durable, scratch and corrosion-resistant and easy to clean.



PERFECT. DESIGN.

# LED MOON DANCE





PERFECT. DESIGN.

# LED MOON DANCE

Die faszinierende Schönheit des Mondes am Nachthimmel war Inspiration für das aktuelle Flaggschiff der ALISEO Kosmetikspiegel. In der Zusammenarbeit mit SIEGER DESIGN als eines der renommiertesten Design Studios in Deutschland entstand nicht nur eine perfekte Formensprache, sondern auch technische Perfektion. Die mondartige Aura des Spiegels entsteht durch den nahtlosen transluzenten Acrylkörper, der sein Licht auf subtile Weise ganzheitlich in alle Richtungen entfaltet.

The fascinating beauty of the moon in the night sky was inspiration for the ALISEO's current flagship cosmetic mirror. In collaboration with SIEGER DESIGN, one of the most renowned design studios in Germany, not only a perfect design language was created, but also technical perfection. The mirror's moon-like aura is created by the seamless translucent acrylic body, which subtly unfolds its light holistically in all directions.

product concept + design: sieger design

SMD-LED-Beleuchtung  
Warmweißes Licht, 3500-4000 K  
Kühles weißes Licht, 5000-5500 K  
T3-Technologie: zwei wählbare Lichttöne  
3-fach-Vergrößerung  
Beleuchteter Tastschalter  
Transluzenter Acryl-Rahmen  
Schutzklasse I  
100-240 V  
Direktanschluss  
Messingkonstruktion

SMD-LED-lighting  
Warm white light, 3500-4000 K  
Cool white light, 5000-5500 K  
T3-Technology: two switchable light tones  
3x magnification  
Lighted touch switch  
Translucent acrylic frame  
Class I  
100-240 V  
Hard wire application  
Brass construction

CE CB  IP44

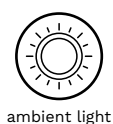

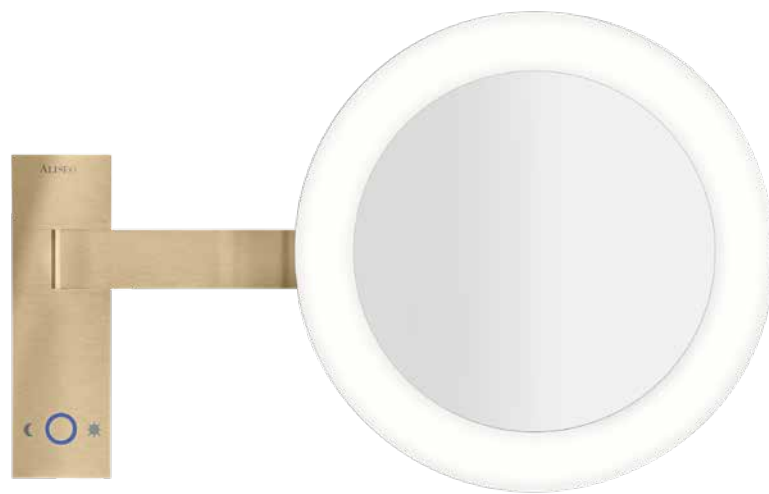

Bronze 301  
bronze 301

# 020758

chrom Schwenkarm ø 240 mm  
chrome single arm ø 240 mm

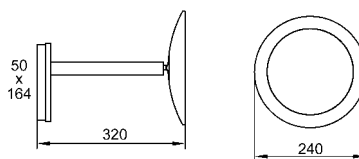

020758



# LED MOON DANCE



# 020759	chrom	Standmodell	ø 240 mm
	chrome	free standing	ø 240 mm

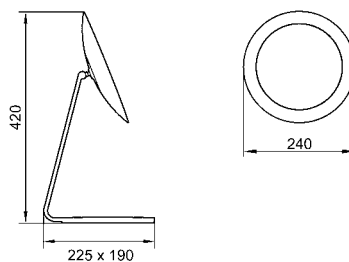

020759





JUST. FEEL. GOOD.

LED ME





JUST. FEEL. GOOD.

## LED ME

Preis/Leistung wird groß geschrieben beim LED ME. Durch optimierte Prozesse und ein schlichtes Design gibt es trotzdem keine Einschränkungen in Sachen Qualität. Die supersparsame LED-Beleuchtung macht nicht nur ein schönes warmes Licht, sondern liefert auch genug Helligkeit durch den transluzenten Acrylrahmen, für eine stimmungsvolle Ambientebeleuchtung.

Price/performance is a top priority with the LED ME. Thanks to optimized processes and a simple design, there are no compromises in terms of quality. The super economical LED lighting not only creates a beautiful warm light, but also provides enough brightness through the translucent acrylic frame for atmospheric ambient lighting.

Acryl-Hintergrundbeleuchtung  
SMD-LED-Beleuchtung  
Warmweißes Licht, 3500-4000 K  
3-fach-Vergrößerung  
Kugelgelenk  
Schutzklasse I  
100-240 V  
Direktanschluss

Acrylic backlight design  
SMD-LED-lighting  
Warm white light, 3500-4000 K  
3x magnification  
Full pivotal adjustment  
Class I  
100-240 V  
Hard wire application



green efficiency



ambient light



NU finishes



magnification



chrom schwarz 211  
black chrome 211

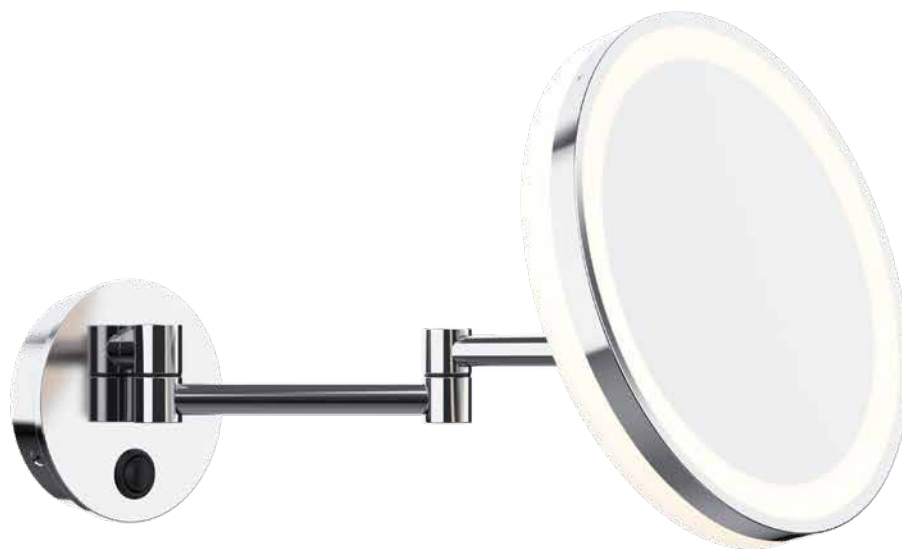

# 020835	chrom chrome	Schwenkarm single arm	ø 220 mm ø 220 mm
----------	-----------------	--------------------------	----------------------

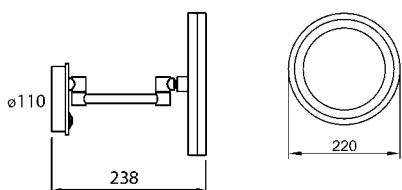

020835

# 020836	chrom chrome	Doppel-Schwenkarm double arm	ø 220 mm ø 220 mm
----------	-----------------	---------------------------------	----------------------

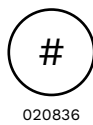
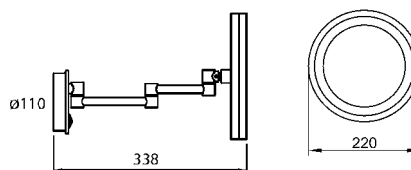

020836



FOR. EVERYONE.

## LED MY

Ein Spiegel für jeden! Mit seinem zeitlosen, schlichten Design ohne Schnickschnack ist der MY Spiegel die perfekte Wahl für alle, die einen eleganten, minimalistischen und funktionalen Look lieben. Eine smarte, budgetfreundliche Option!

A mirror for everyone! With its timeless, simple, no-frills design, the MY mirror is the perfect choice for anyone who loves an elegant, minimalist and functional look. A smart, budget-friendly option!

SMD-LED-Beleuchtung  
Warmweißes Licht, 3500-4000 K  
3-fach-Vergrößerung  
Doppelwalzengelenk  
Schutzklasse I  
100-240 V  
Direktanschluss

SMD-LED-lighting  
Warm white light, 3500-4000 K  
3x magnification  
Full pivotal adjustment  
Class I  
100-240 V  
Hard wire application



green efficiency



NU finishes



magnification



Bronze 301  
bronze 301



NEW

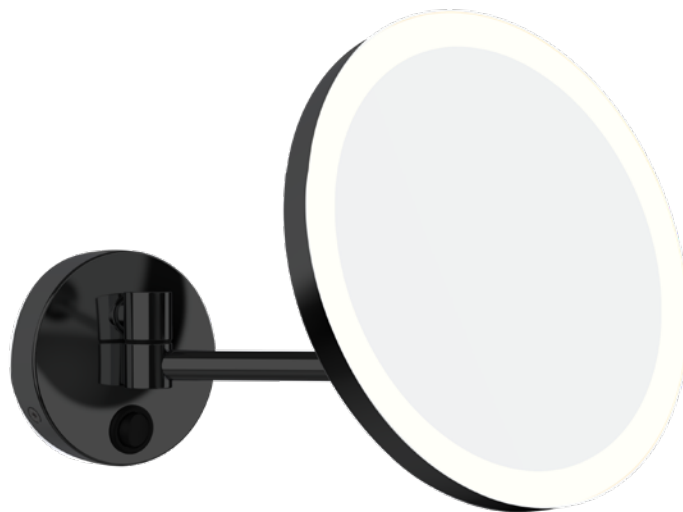

schwarz matt  
black matt

# 020843	chrom	Schwenkarm	ø 220 mm
	chrome	single arm	ø 220 mm
# 020843.102	schwarz matt	Schwenkarm	ø 220 mm
	black matt	single arm	ø 220 mm

# 020844	chrom	Doppel-Schwenkarm	ø 220 mm
	chrome	double arm	ø 220 mm
# 020844.102	schwarz matt	Doppel-Schwenkarm	ø 220 mm
	black matt	double arm	ø 220 mm

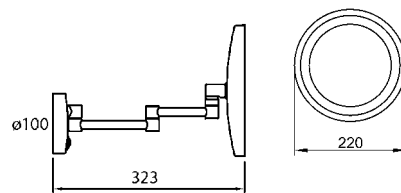
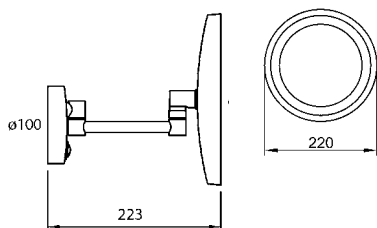

020843



020843.102



020844



020844.102

# LED SATURN



Nickel 207  
nickel 207



# 020743	chrom chrome	Schwenkarm single arm	ø 220 mm ø 220 mm
----------	-----------------	--------------------------	----------------------

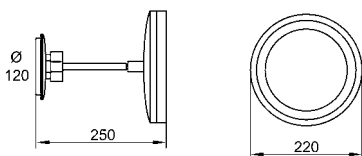

020743

# 020744	chrom chrome	Doppel-Schwenkarm double arm	ø 220 mm ø 220 mm
----------	-----------------	---------------------------------	----------------------

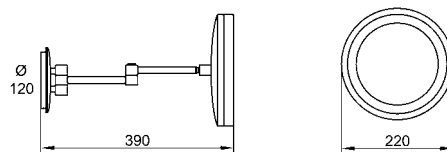

020744



ALL-ENCOMPARRING. CLASSIC. LUXUS.

## LED SATURN

Der beleuchtete Kosmetikspiegel für anspruchsvolle Nutzende. LED SATURN. Dank unserer exklusiven Two-Tone-Touch-Technologie wechselt die Lichtfarbe mit einer Berührung zwischen kalt- und warmweiß. Möglich wird das durch zwei unabhängige LED-Systeme im Inneren des Spiegels. Und weil wir auch bei diesen unsichtbaren Komponenten nur die besten verbauen, ist LED SATURN super sparsam und mit einer wartungsfreien Laufzeit bis zu 50.000 Stunden.

The illuminated cosmetic mirror for discerning users. LED SATURN. Thanks to our exclusive Two-Tone-Touch technology, the light color changes between cold and warm white with a single touch. This is possible by two independent LED systems inside the mirror. And because we also use only the best components even if it comes to the invisible ones, LED SATURN is super economical and has a maintenance-free life span of up to 50,000 hours.

SMD-LED-Beleuchtung  
 Warmweißes Licht, 3500-4000 K  
 Kühles weißes Licht, 5000-5500 K  
 T3-Technologie: zwei wählbare Lichttöne  
 3-fach-Vergrößerung  
 Beleuchteter Tastschalter  
 Kugelgelenk  
 Schutzklasse I  
 100-240 V  
 Direktanschluss  
 Messingkonstruktion

SMD-LED-lighting  
 Warm white light, 3500-4000 K  
 Cool white light, 5000-5500 K  
 T3-Technology: two switchable light tones  
 3x magnification  
 Lighted touch switch  
 Full pivotal adjustment  
 Class I  
 100-240 V  
 Hard wire application  
 Brass construction





Nickel gebürstet 307  
brushed nickel 307



Messing 206  
brass 206





Chrom 100  
chrome 100

CONTEMPORARY. INDEPENDENT.  
LED INTERFACE





NEW

CONTEMPORARY. INDEPENDENT.

## LED INTERFACE

LED INTERFACE vereint alle Anforderungen der heutigen Zeit. Dank seines Infrarotsensors leuchtet das Licht nur, wenn der Spiegel in Benutzung ist. Zusammen mit der besten LED-Technologie ist er dadurch ultrasparsam. So ist es möglich diesen beleuchteten Kosmetikspiegel wahlweise mit Batterien oder Akkus zu betreiben.

LED INTERFACE combines all of today's requirements. Thanks to its infrared sensor, the light is only switched on when the mirror is in use. Together with the best LED technology, this makes it ultra-economical. It is therefore possible to operate this illuminated cosmetic mirror on battery power. A power connection is not necessary.

### SMD-LED-Beleuchtung

Warmweißes Licht, 3500-4000 K

3-fach-Vergrößerung

Batteriebetrieben 4 x 18650 Akkubatterien

USB-Aufladung

Ein-/Ausschaltung durch Infrarotsensor

Messing-Komponenten

Schwenk-/Kippgelenk (Schwenkarm)

Kippgelenk (Standspiegel)

Adapterplatte für bessere Stabilität

### SMD-LED-lighting

Warm white light, 3500-4000 K

3x magnification

Battery powered 4 x 18650 rechargeable batteries

USB charging

Switched on/off by infrared sensor

Brass components

Full pivotal adjustment

Adapter plate for improved stability

CE



battery powered



sensor



automatic switch-off



green efficiency



NU finishes



magnification

USB  
charging



Automatisches Einschalten durch Gesichtsannäherung. Ein Infrarot-Sensor aktiviert die automatische Ein-/Ausschaltung der LED-Beleuchtung im transluzenten Acrylrings im Abstand von 20 cm.  
Lights automatically as your face approaches. Auto ON/OFF infrared sensor activates a translucent acrylic edge LED lighting system. Operational up to 20 cm.

# 020859 chrom Schwenkarm ø 220 mm  
chrome single arm ø 220 mm

# 020858 chrom Standmodell ø 220 mm  
chrome free standing ø 220 mm

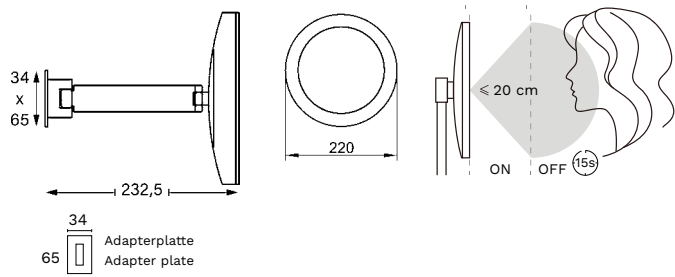

#  
020859

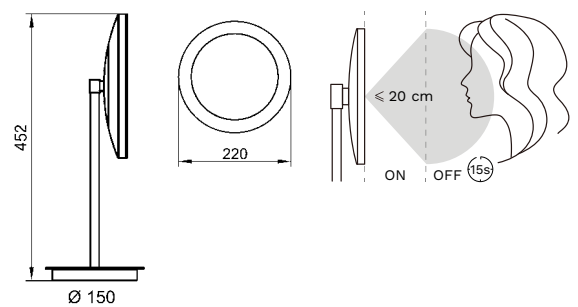

#  
020858



schwarz matt  
black matt

## STYLE. AND. FUNCTION. LED CITY LIGHT

Der LED CITY LIGHT setzt neue Maßstäbe in Stil und Funktion. Mit einem Durchmesser von 250 mm bietet er ausreichend Fläche für eine komfortable und umfassende Nutzung. Sein modernes Design, erhältlich in einer eleganten schwarz-matten Pulverbeschichtung oder einem glänzenden Chrom-Finish, verleiht ihm einen zeitgemäßen und stilvollen Look.

The LED CITY LIGHT sets new standards in style and function. With a diameter of 250 mm, it offers sufficient surface area for comfortable and comprehensive use. Its modern design, available in an elegant black matt powder coating or a shiny chrome finish, gives it a contemporary and stylish look.

SMD-LED-Beleuchtung  
Warmweißes Licht, 3500-4000 K  
3-fach-Vergrößerung  
Doppelwalzengelenk  
Schutzklasse I  
100-240 V  
Direktanschluss

SMD-LED-lighting  
Warm white light, 3500-4000 K  
3x magnification  
Full pivotal adjustment  
Class I  
100-240 V  
Hard wire application



green efficiency



NU finishes



magnification



schwarz matt  
black matt



# 020677 chrom Schwenkarm ø 250 mm  
chrome single arm ø 250 mm

# 020657 chrom Doppel-Schwenkarm ø 250 mm  
chrome double arm ø 250 mm

# 020801 schwarz matt Doppel-Schwenkarm ø 250 mm  
black matt double arm ø 250 mm

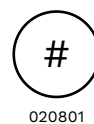
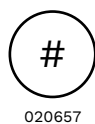
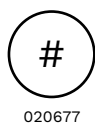
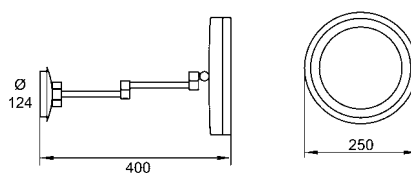
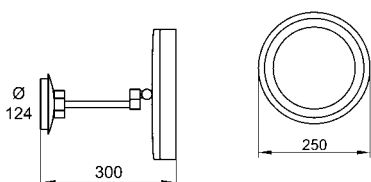

MIRA

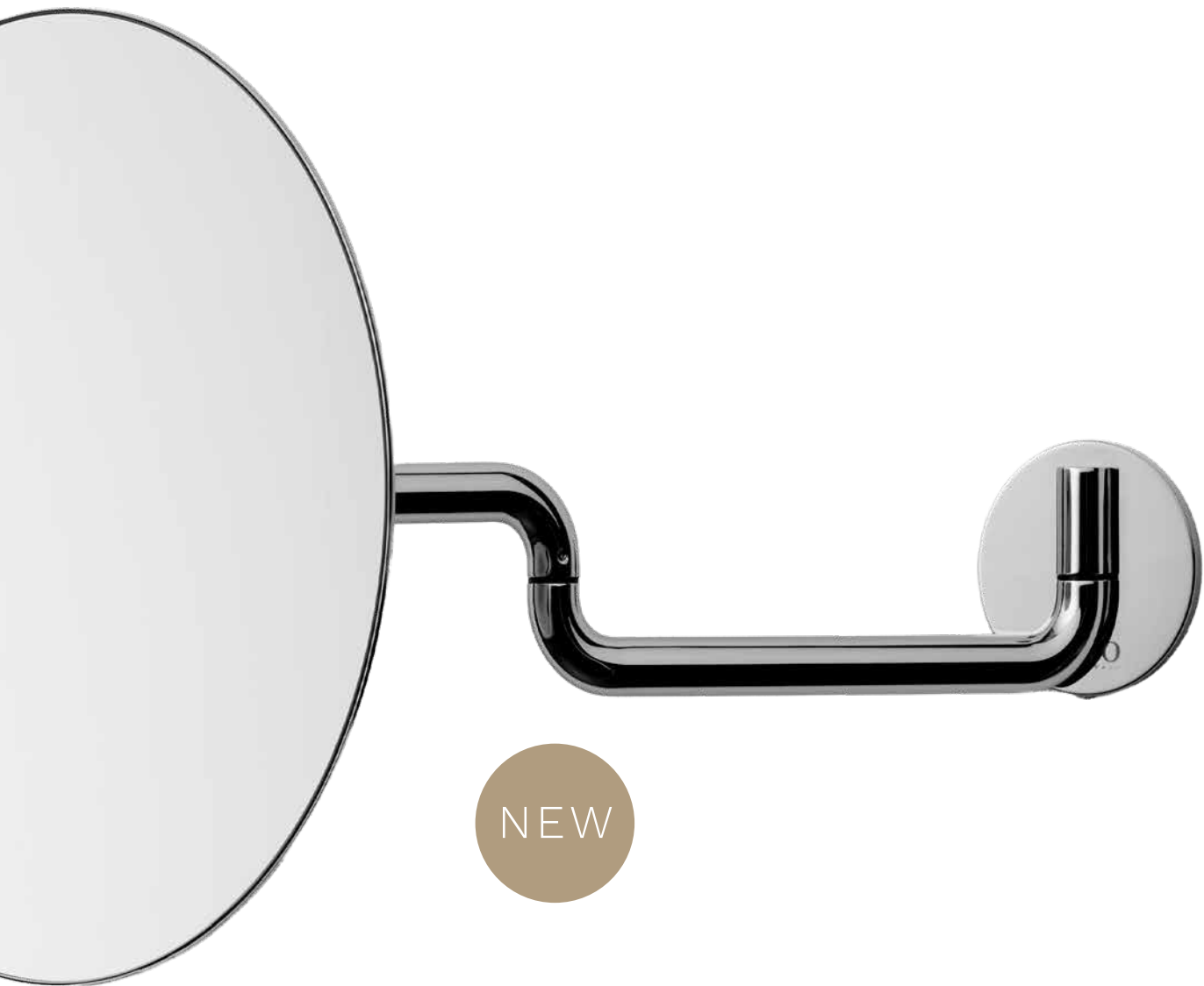

HARMONY. PURE. ELEGANCE.

## MIRA

Der Spiegel MIRA zeigt, wie schön reine Schlichtheit sein kann. Ohne Beleuchtung konzentriert er sich auf das Wesentliche und strahlt gerade dadurch eine ruhige, zeitlose Eleganz aus. Der geformte Arm verleiht dem Design eine harmonische, weiche Linie und sorgt zugleich für angenehme Bedienbarkeit.

The mirror MIRA shows how beautiful pure simplicity can be. Without lighting, it focuses on the essentials and thus radiates a calm, timeless elegance. The shaped arm gives the design a harmonious, soft line and at the same time ensures pleasant usability.

5-fach-Vergrößerung  
Kugelgelenk  
Verdeckte Montageeinheit

5x magnification  
Full pivotal adjustment  
Covered backplate





# 020867	chrom	Schwenkarm	ø 200 mm
	chrome	single arm	ø 200 mm

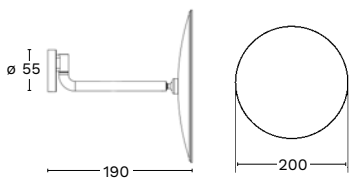

020867

# 020868	chrom	Doppel-Schwenkarm	ø 200 mm
	chrome	double arm	ø 200 mm

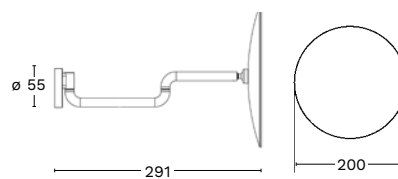

020868



CLASSIC. MINIMALIST.

## COSMO MINIMALIST

COSMO MINIMALIST ist so wunderbar schlicht, wie ein Kosmetikspiegel nur sein kann. Ohne Beleuchtung ist er auf das absolut Wesentliche reduziert und macht damit eine gute Figur. Beste Materialien machen ihn in jeder Hinsicht zu einem Begleiter für die Ewigkeit.

COSMO MINIMALIST is as wonderfully simple as a cosmetic mirror can be. Without lighting, it is reduced to the absolute essentials and cuts a fine figure. The best materials make it a companion for eternity in every respect.

3-fach-Vergrößerung  
Schwenk-/Kippgelenk  
Verdeckte Montageeinheit

3x magnification  
Full pivotal adjustment  
Covered backplate





schwarz matt  
black matt

# 020488	chrom chrome	Standmodell free standing	Ø 200 mm Ø 200 mm
# 020805	schwarz matt black matt	Standmodell free standing	Ø 200 mm Ø 200 mm

# 020607	chrom chrome	Schwenkarm single arm	Ø 200 mm Ø 200 mm
# 020804	schwarz matt black matt	Schwenkarm single arm	Ø 200 mm Ø 200 mm

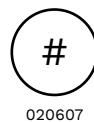
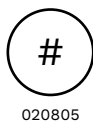
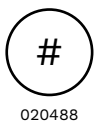
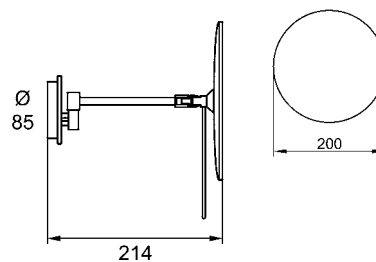
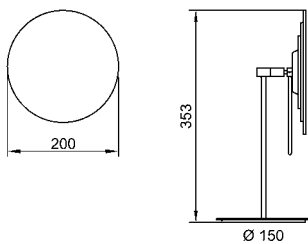

JUST. FEEL. GOOD.

FACE





goldoptik 203  
gold optic 203

NU finishes

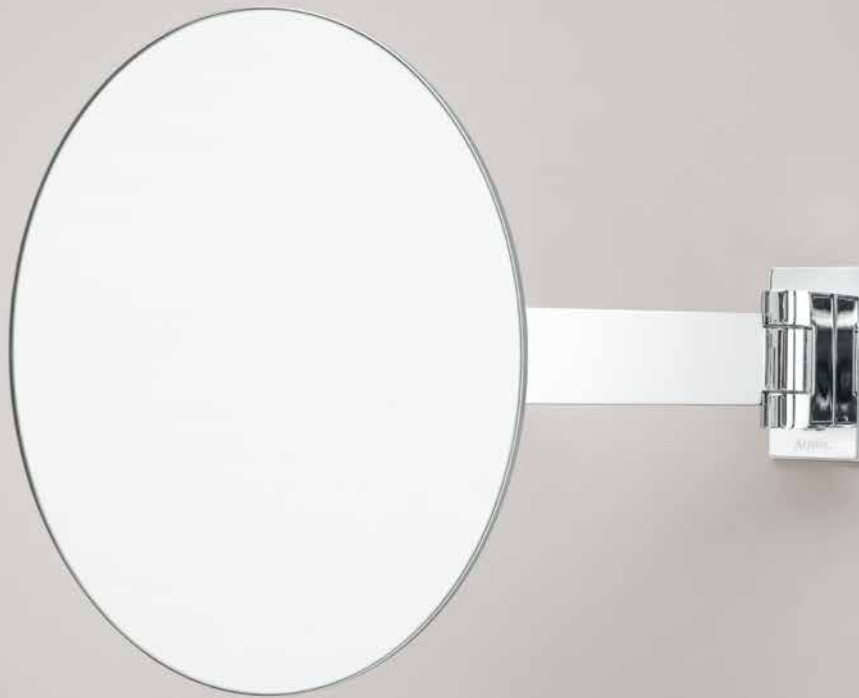

JUST. FEEL. GOOD.

## FACE

FACE vereint randlose Eleganz mit einer cleveren Klapptechnik. Durch sie lässt er sich ultraflach an die Wand klappen und ist an feiner Ästhetik kaum zu übertreffen. Auf eine Beleuchtung haben wir bewusst verzichtet und so ist ein Elektroanschluss nicht nötig. Weniger ist auch hier wieder mehr.

FACE combines frameless elegance with clever folding technology. It can be folded ultra-flat against the wall and is hard to beat in terms of fine aesthetics. We have deliberately avoided using lighting, so there is no need for an electrical connection. Once again, less is more.

3-fach-Vergrößerung  
5-fach-Vergrößerung (Standmodell)  
Schwenk-/Kippgelenk  
Kugelgelenk (Standmodell)  
Verdeckte Montageeinheit  
Adapterplatte für bessere Stabilität

3x magnification  
5x magnification (free standing)  
Full pivotal adjustment  
Covered backplate  
With adapter plate for more stability



NEW

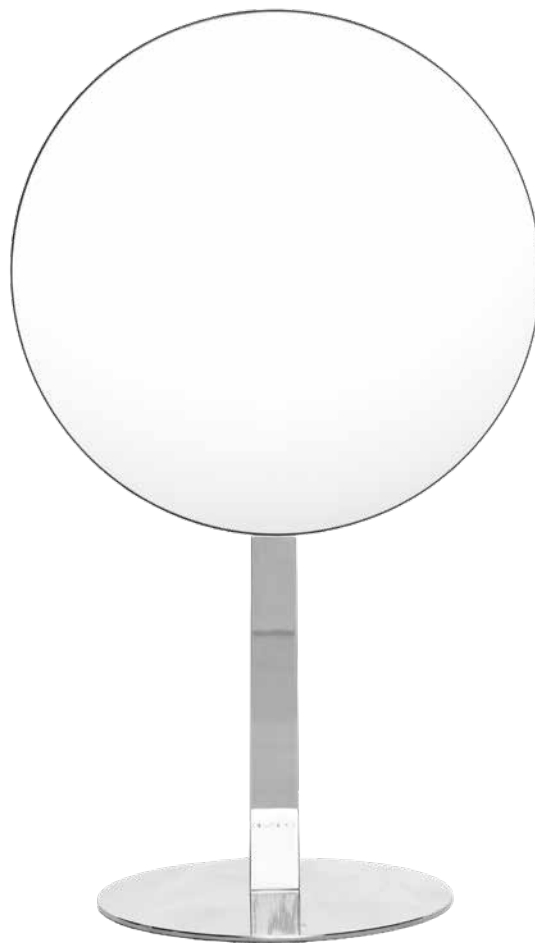

# 020866 chrom Standmodell ø 200 mm  
chrome free standing ø 200 mm

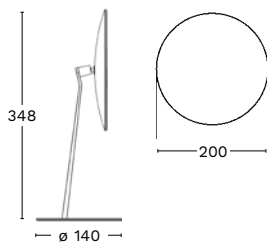

# 020831 chrom Schwenkarm ø 200 mm  
chrome single arm ø 200 mm

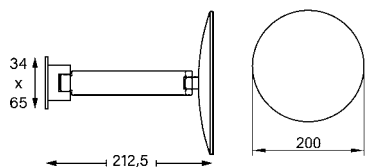

34  
65  
Adapterplatte  
Adapter plate



020831

# 020829 chrom Doppel-Schwenkarm ø 200 mm  
chrome double arm ø 200 mm

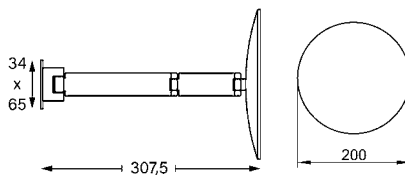

34  
65  
Adapterplatte  
Adapter plate



020829



020866



schwarz matt  
black matt

SIMPLE. FUNCTIONAL. DURABLE.

## CONCIERGE COLLECTION

Unsere Spiegel überzeugen durch hochwertige Verarbeitung, präzise Vergrößerung und zeitloses Design. Sie sind langlebig, pflegeleicht und ideal für den täglichen Einsatz im Hotelbad. Dank verschiedener Farben und Ausführungen fügen sie sich flexibel in jedes Interieur ein und bieten Gästen eine komfortable, detaillierte Spiegelansicht.

Our mirrors stand out with their high-quality workmanship, precise magnification, and timeless design. They are durable, easy to maintain, and ideal for daily use in hotel bathrooms. Available in various colours and finishes, they adapt flexibly to any interior and provide guests with a comfortable, detailed reflection.

Planspiegel und 3-fach-Vergrößerung

Verdeckte Montageeinheit

Messing-Komponenten

Drehgelenk

Plain mirror an 3x magnification

Covered backplate

Brass components

Full pivotal adjustment

# 020802	schwarz matt	Doppel-Schwenkarm	ø 200 mm
	black matt	double arm	ø 200 mm

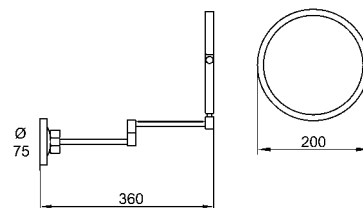

plain mirror

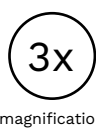

magnification

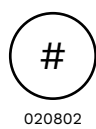

020802



DOPPELSPIEGEL – FLEXIBEL UND KOMFORTABEL

Ob Detailarbeit oder Gesamtbild: Eine Seite vergrößert 3-fach, die andere zeigt das natürliche Spiegelbild. Einfach wenden – praktisch, intuitiv, perfekt für jeden Gast.

DOUBLE-SIDED MIRROR – FLEXIBLE & CONVENIENT

For precision or the perfect overview: one side offers 3x magnification, the other shows a natural reflection. Simply flip – practical, intuitive, ideal for every guest.

Planspiegel und 3-fach-Vergrößerung

Verdeckte Montageeinheit

Messing-Komponenten

Drehgelenk

Plain mirror and 3x magnification

Covered backplate

Brass components

Full pivotal adjustment

# 020506

chrom	Schwenkarm	∅ 200 mm
chrome	single arm	∅ 200 mm

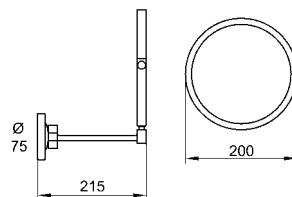

plain mirror



magnification



020506

NEW

PERFECT. DESIGN.

# BATHROOM MIRRORS







NEW

ROUND. BRUSHED. STYLISH.

## ORE

Der runde Spiegel ORE bringt moderne Eleganz in das Badezimmer. Sein filigraner, goldfarbener Rahmen aus gebürstetem Aluminium setzt hochwertige Akzente und verleiht dem Spiegel eine edle und zeitlose Ausstrahlung. Ob als stilvoller Mittelpunkt über dem Waschtisch oder als dekoratives Highlight an einer freien Wand – dieser Spiegel bringt Harmonie und Leichtigkeit in jeden Raum.

The round mirror ORE brings modern elegance to the bathroom. Its delicate, gold-colored frame made of brushed aluminum adds high-quality accents and gives the mirror a sophisticated and timeless look. Whether as a stylish focal point above the washbasin or as a decorative highlight on a free wall, this mirror brings harmony and lightness to any room.

# 020874	gold gebürstet	ø 600 mm
	brushed gold	ø 600 mm

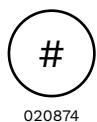
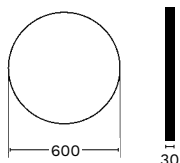

020874

# 020875	gold gebürstet	ø 800 mm
	brushed gold	ø 800 mm

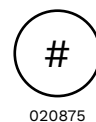
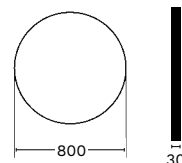

020875



NEW

OVAL. BRUSHED. STYLISH.

## JOY

Der ovale Spiegel JOY setzt stilvolle Akzente in deinem Badezimmer. Der feine goldene Rahmen aus gebürstetem Aluminium verleiht dem Spiegel einen modernen und edlen Look und sorgt für eine hochwertige Optik. Ob vertikal oder horizontal aufgehängt – dieser dekorative Spiegel passt sich perfekt jedem Raumkonzept an und bringt Eleganz und Funktionalität in Einklang.

The oval mirror JOY adds stylish accents to your bathroom. The delicate golden frame made of brushed aluminum gives the mirror a modern, elegant look and ensures a high-quality appearance. Whether hung vertically or horizontally, this decorative mirror fits perfectly into all room concept and harmonizes elegance and functionality.

# 020876	gold gebürstet	400 x 800 mm
	brushed gold	400 x 800 mm

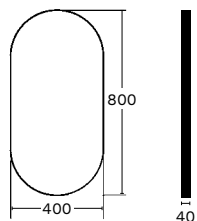

020876



H O T E L B A D  
HOTEL BATHROOM



LUXURY. YOU. CAN. FEEL.

# TOWEL HEATERS

Mit ihrem modernen Design und edlen Materialien verwandeln sie jedes Bad in eine Wohlfühloase. Die innovative Carbonfaser-Technologie sorgt nicht nur für angenehme Wärme, sondern auch für maximale Energieeffizienz. Ob kuschelwarme Handtücher nach dem Duschen oder ein Hauch von Wellness. Praktische Extras wie der Steckdosenanschluss und die pflegeleichte Anti-Fingerprint-Oberfläche machen den Komfort perfekt. Dank patentiertem Design stehen die Heizkörper für Innovation, Stil und Nachhaltigkeit.

With their modern design and premium materials, they transform any bathroom into a true oasis of well-being. The innovative carbon fiber technology provides not only gentle warmth but also maximum energy efficiency. Whether it's luxuriously warm towels after a shower or a touch of everyday wellness. Practical features such as the plug-in connection and the easy-care anti-fingerprint surface make comfort complete. Thanks to their patented design, these towel radiators stand for innovation, style, and sustainability.







NEW

LUXURY. YOU. CAN. FEEL.

## AMBER PRO

Der AMBER PRO vereint modernste Carbonfaser-Technologie, flexible 30–65 °C Temperaturregelung und eine praktische Timer-Funktion in einem preisgekrönten Design. Sein hochwertiges chrom gebürstetes Finish verleiht jedem Hotelbad eine exklusive und zeitlose Ästhetik. Als Gewinner des German Design Award 2024 überzeugt er nicht nur technisch, sondern auch visuell – eine Premium-Lösung für Hotels, die ihren Gästen herausragenden Komfort und Eleganz bieten möchten.

The AMBER PRO combines modern carbon fiber technology, flexible 30–65 °C temperature control and a practical timer function in an award-winning design. Its high-quality brushed chrome finish lends every hotel bathroom an exclusive and timeless aesthetic. As the winner of the German Design Award 2024, it impresses not only technically but also visually – a premium solution for hotels that want to offer their guests outstanding comfort and stylish elegance.

Direktanschluss  
Optional mit zusätzlichem Kabel und Stecker zum Anschluss an Steckdose  
Rohrdurchmesser  $\varnothing$  19 mm  
Rechtsausführung  
Digitalregler  
Edelstahl 304  
Schutzklasse I

Hard wire application  
Optional with additional cord and plug for plug-in application  
Pipe diameter  $\varnothing$  19 mm  
Right-hand version  
Digital controller  
Stainless steel 304  
Class I



pipes



30–65°C



fingerprint resistant



992363

# 992363	chrom gebürstet	5 Rohre	75 W
	brushed chrome	5 pipes	75 W

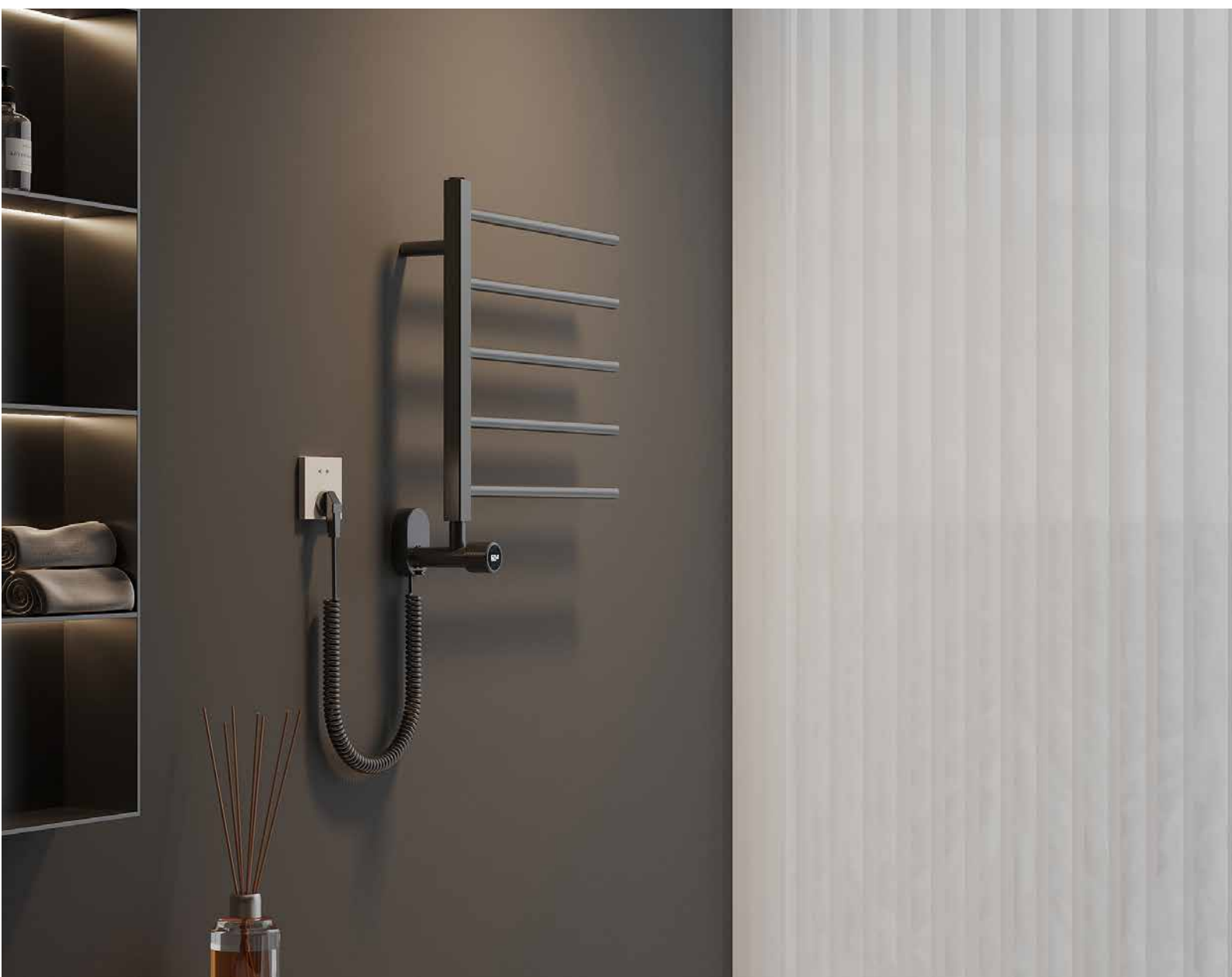
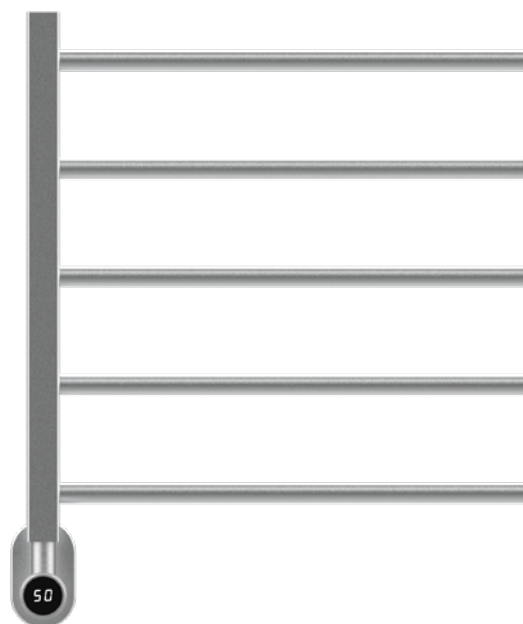
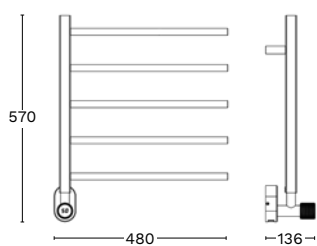



NEW

LUXURY. YOU. CAN. FEEL.

# PEARL PRO

Der PEARL PRO ist ein eleganter Handtuchwärmer in edlem Chrom, ausgestattet mit moderner Carbon-faser-Technologie für schnelles, sicheres und energieeffizientes Erwärmen. Dank Timer-Funktion und einer flexibel einstellbaren Temperaturspanne von 30–65 °C bietet er maximalen Komfort und perfekte Anpassung für jedes Hotelbad. Stilvoll, leistungsstark und effizient – der PEARL PRO setzt neue Standards in der Hotellerie.

The PEARL PRO is an elegant towel warmer in sophisticated chrome, equipped with modern carbon fiber technology for fast, safe and energy-efficient heating. Thanks to its timer function and a flexibly adjustable temperature range of 30–65 °C, it offers maximum comfort and perfect adaptation for every hotel bathroom. Stylish, powerful and efficient - the PEARL PRO sets new standards in the hotel industry.

Direktanschluss  
 Rohrdurchmesser ø 19 mm  
 Rechtsausführung  
 Digitalregler  
 Edelstahl 304  
 Schutzklasse I

Hard wire application  
 Pipe diameter ø 19 mm  
 Right-hand version  
 Digital controller  
 Stainless steel 304  
 Class I





# 992364	chrom	3 Rohre	45 W
	chrome	3 pipes	45 W

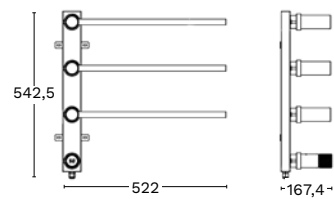

# 992365	chrom	4 Rohre	68 W
	chrome	4 pipes	68 W

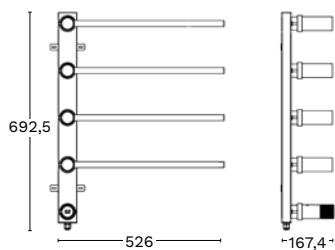



NEW

LUXURY. YOU. CAN. FEEL.

# R O C K

Der Handtuchwärmer ROCK verbindet modernste Carbonfaser-Technologie mit einem edlen schwarz-matten Design – perfekt für anspruchsvolle Hotelbäder. Er erwärmt Handtücher schnell, sicher und energieeffizient auf angenehme 50 °C. Langlebig, stilvoll und effizient: ROCK sorgt für spürbaren Gästekomfort und eine moderne, hochwertige Raumatmosphäre.

The towel heater ROCK combines modern carbon fiber technology with an elegant black matt design - perfect for sophisticated hotel bathrooms. It heats towels quickly, safely and energy-efficiently to a comfortable 50°C. Durable, stylish and efficient: ROCK ensures noticeable guest comfort and a modern, high-quality room atmosphere.

Direktanschluss  
 Optional mit zusätzlichem Kabel und Stecker zum Anschluss an Steckdose  
 Rohrdurchmesser ø 22 mm  
 Rechtsausführung  
 Druckknopfschalter  
 Kohlenstoffstahl  
 Schutzklasse I

Hard wire application  
 Optional with additional cord and plug for plug-in application  
 Pipe diameter ø 22 mm  
 Right-hand version  
 Push button switch  
 Carbon steel  
 Class I





# 992361	schwarz	4 Rohre	75 W
	black	4 pipes	75 W

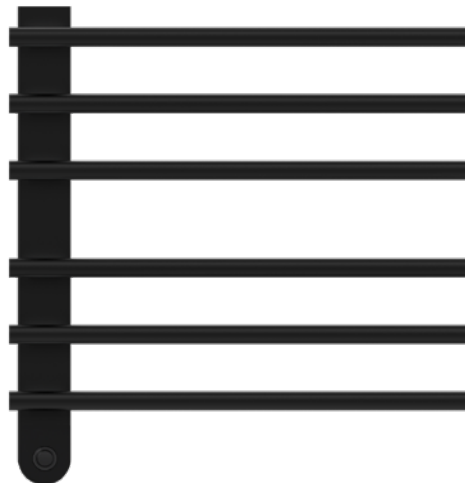
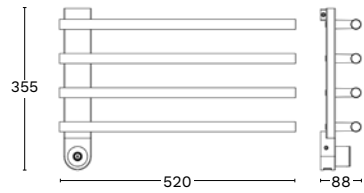

# 992362	schwarz	6 Rohre	135 W
	black	6 pipes	135 W

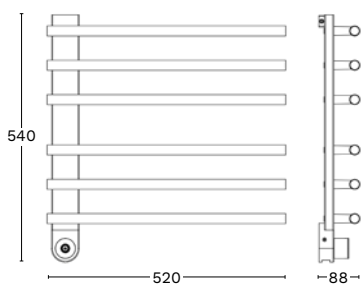

SOLUTIONS. FOR. MANY. DETAILS.

# BATHROOM ACCESSORY LINES

ARCHITECTO

MAXIMA

TECNO

NOW

NEXXUS

COMPLEMENTARY









Mit den NU finishes gestalten Sie alle Kosmetikspiegel und Badaccessoires in Ihrer Wunschoberfläche und -farbe. Wir setzen diese dann als hochwertige PVD-Beschichtung um. Brillant, langlebig, kratz- und korrosionsbeständig und einfach zu reinigen.

With NU finishes, you can customize all cosmetic mirrors and bathroom accessories in the surface and color of your choice. We then apply these as a high-quality PVD coating. Brilliant, durable, scratch and corrosion-resistant and easy to clean.



GUARANTEE  
chrome finish

Auf unsere verchromten Oberflächen gewähren wir eine freiwillige Garantie von 10 Jahren. Bitte beachten Sie unsere Montage- und Pflegehinweise.

We grant a voluntary guarantee of 10 years on our chrome-plated surfaces. Please note our installation and care instructions.



GUARANTEE  
PVD

Unsere Oberflächen in Sonderfarbe entstehen durch PVD-Beschichtung – ob hochglanz, gebürstet oder matt. Sie sind langlebig, kratzfest und feuchtigkeitsresistent. Dafür gewähren wir 5 Jahre freiwillige Garantie. Bitte beachten Sie unsere Montage- und Pflegehinweise.

Our special-color surfaces are created using PVD coating – whether high-gloss, brushed, or matte. They are durable, scratch-resistant, and moisture-resistant. For this, we offer a voluntary 5-year warranty. Please note our installation and care instructions.



GUARANTEE  
powder coating

Mattes Schwarz und Weiß – echte Klassiker. Durch Pulverbeschichtung erhalten sie ihre edle Ausstrahlung und besondere Beständigkeit. Dafür geben wir 2 Jahre Garantie. Bitte beachten Sie unsere Montage- und Pflegehinweise

Matte black and white – true classics. Powder coating gives them their elegant appearance and exceptional durability. We provide a 2 year warranty. Please observe our installation and care instructions.



UNDERSTATED. DESIGN.

## ARCHITECTO

Schlicht und zurückhaltend versprüht die ARCHITECTO-Serie das Flair eines Oberklasse-Hotels. Sie trägt nicht auf, sondern besticht durch ihre Qualität und hinterlässt beim Gast ein unaufdringliches Gefühl von Luxus.

Simple and understated, the ARCHITECTO range exudes the flair of an upper-class hotel. It is not overbearing but impresses with its quality and simply leaves guests with an unobtrusive feeling of luxury.



GUARANTEE  
chrome finish





# 770005

Haken  
Hook

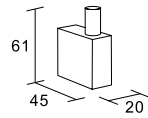

# 770011

Seifenhalter  
Keramische Schale  
Soap Dish  
Ceramic Dish

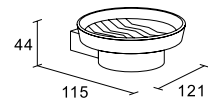

# 770016

Handtuchhalter  
Towel Rail

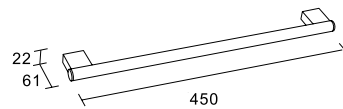

# 770006

Papierrollenhalter  
Toilet Roll Holder

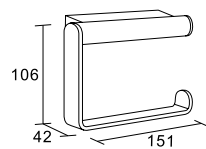

# 770017

Papierrollenhalter  
Toilet Roll Holder

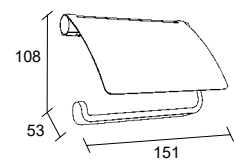



# 770012  
Seifenspender  
Keramik  
Soap Dispenser  
Ceramic

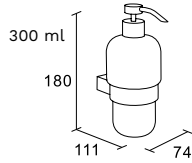

# 770009  
Becherhalter  
Keramikbecher  
Tumbler Holder  
Ceramic Tumbler

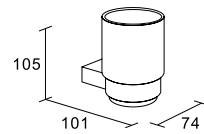

# 770018  
Sicherheits-Haltegriff  
Safety Grab Bar

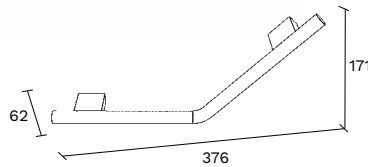

# 770007  
Reserverollenhalter  
Spare Roll Holder

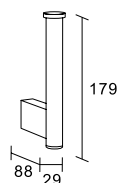

# 770008  
WC-Bürstengarnitur  
Keramikbehälter  
Toilet Brush Holder  
Ceramic Case

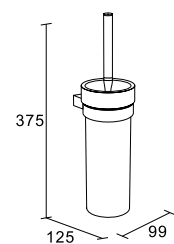

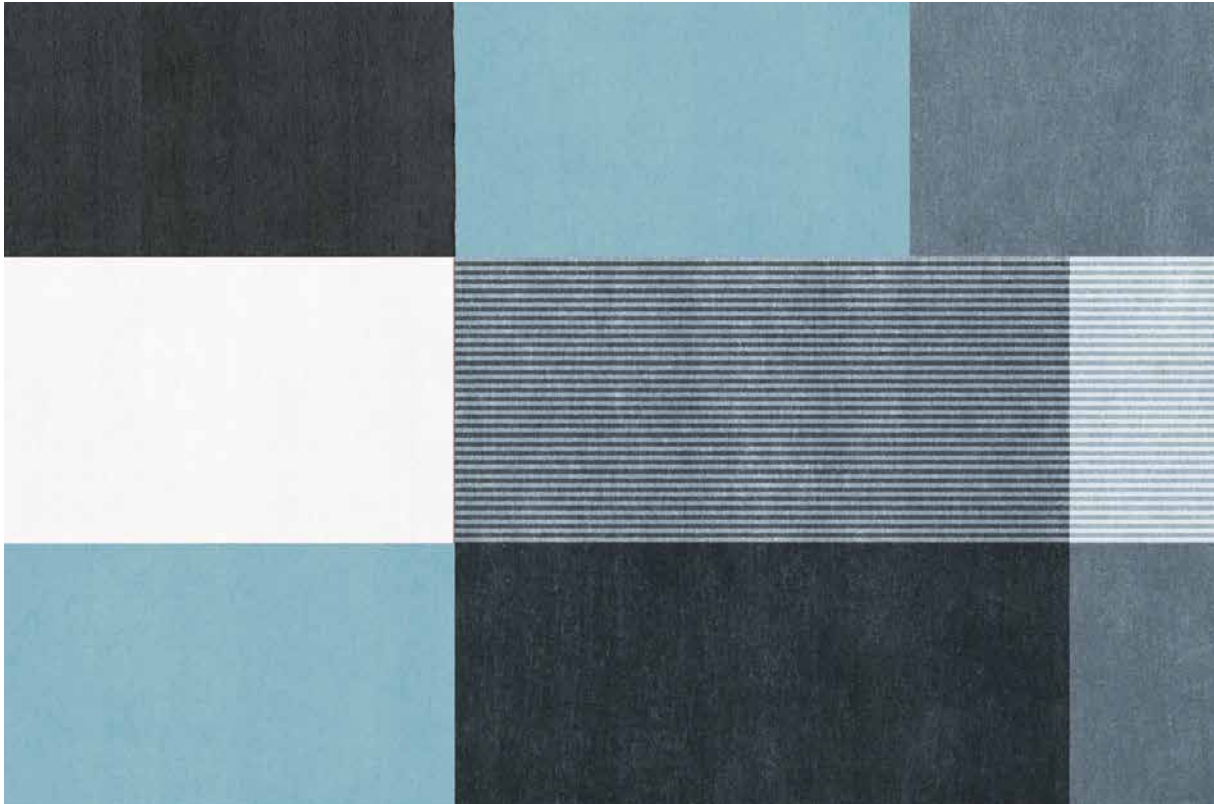

UNCOMPROMISINGLY. MODERN.

## MAXIMA

Diese Accessoire-Serie zeigt Kante. Und hebt sich damit selbstbewusst ab, von gewohnten Ästhetiken, die uns seit Generationen begleiten und dadurch oft in den Hintergrund rücken. Da ist es nur logisch, dass MAXIMA auch in Sachen Farbe Kante zeigt: schwarz oder weiß. Natürlich matt. Mehr braucht es nicht. Denn diese beiden Farben unterstreichen nicht nur perfekt die zeitgemäße Linienführung der Badezimmerserie, sondern treffen den Nerv der Zeit und komplettieren modernes Interior Design mühelos.

This accessory line takes a firm stand. And thus stands out self-confidently from the usual aesthetics that have surrounded us for generations and often fade into the background as a result. So it is only logical that MAXIMA also takes a firm stand when it comes to color: black or white. Matt, of course. That's all it takes. Because these two colors not only perfectly underline the contemporary contours of the bathroom series, but also capture today's spirit and effortlessly complete modern interior design.



GUARANTEE  
powder coating



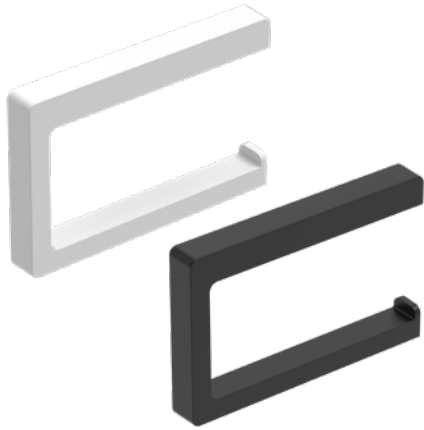

# 793003 - schwarz matt. black matt  
# 794003 - weiß matt. white matt

Papierrollenhalter  
Toilet Roll Holder

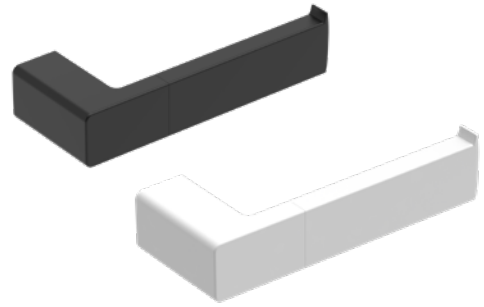
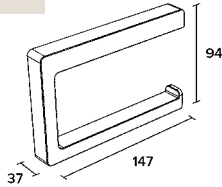

# 793002 - schwarz matt. black matt  
# 794002 - weiß matt. white matt

Papierrollenhalter  
Toilet Roll Holder

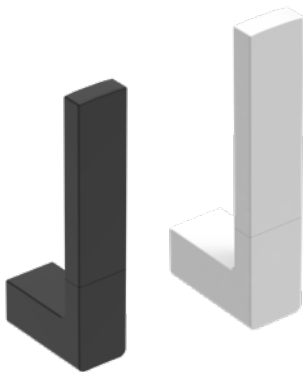
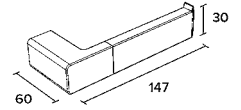

# 793004 - schwarz matt. black matt  
# 794004 - weiß matt. white matt

Reserverollenhalter  
Spare Roll Holder

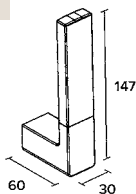

# 030672 - schwarz matt. black matt  
# 030674 - weiß matt. white matt

WC-Bürstengarnitur  
Wandmontage oder Standmodell  
Herausnehmbarer Kunststoffeinsatz.  
Toilet Brush Holder  
Wall mounted or free standing model  
Removable plastic insert

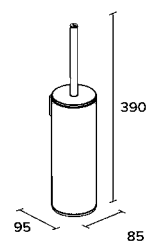

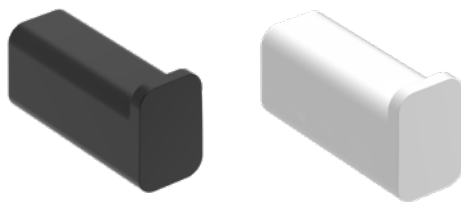

# 793001 - schwarz matt. black matt

# 794001 - weiß matt. white matt

Haken  
Hook

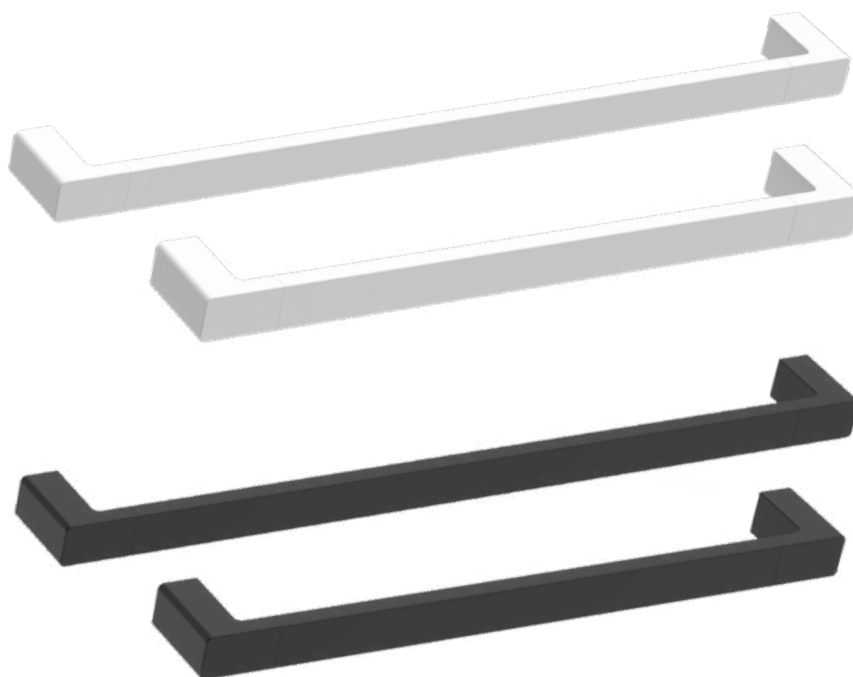
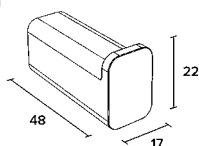

# 793005 - schwarz matt. black matt  
# 794005 - weiß matt. white matt

Handtuchhalter  
Towel Rail

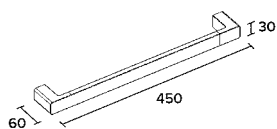

# 793006 - schwarz matt. black matt  
# 794006 - weiß matt. white matt

Handtuchhalter  
Towel Rail

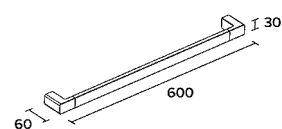



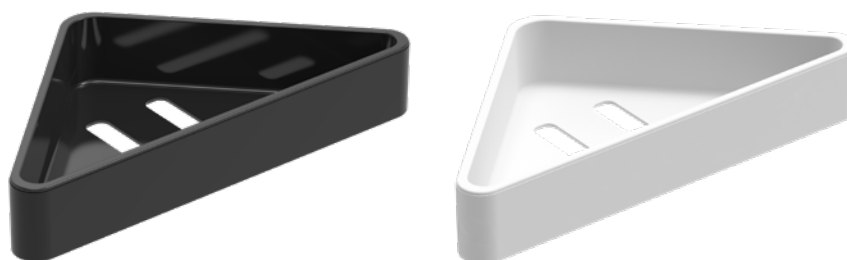

# 033671 - schwarz. black  
# 034671 - weiß. white

Eckseifenkörbchen  
Edelstahl mit matter  
Pulverbeschichtung  
Herausnehmbarer ABS-  
Kunststoffeinsatz  
Corner Soap basket  
Stainless steel with  
matt powder coating  
Removable, ABS plastic insert

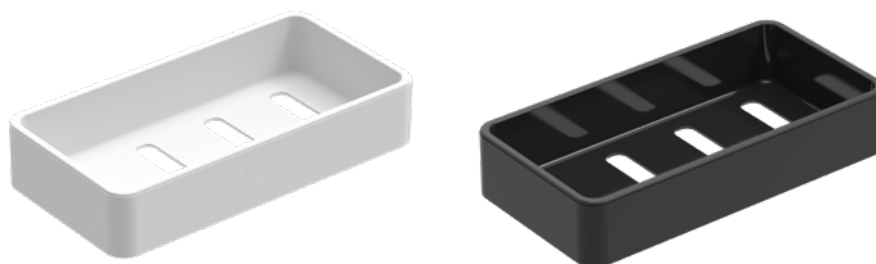
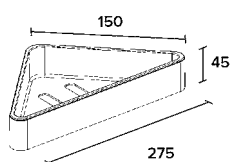

# 033677 - schwarz. black  
# 034677 - weiß. white

Seifenkörbchen  
Edelstahl mit matter  
Pulverbeschichtung  
Herausnehmbarer ABS-  
Kunststoffeinsatz  
Corner Soap basket  
Stainless steel with  
matt powder coating  
Removable, ABS plastic insert

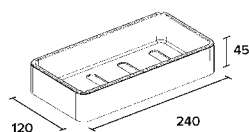



THE. STANDARD.

## TECNO

Ohne Schnörkel. Höchste Qualität. Mit TECNO setzte ALISEO einen Designstandard, der bis heute Bestand hat und nichts an Aktualität eingebüßt hat. Doch nicht nur das Design ist von Dauer, auch die Qualität ist beispiellos. Und deshalb geben wir 10 Jahre Garantie auf die Oberfläche.

Straight forward. No frills. Highest quality. With TECNO, ALISEO set a design standard that has endured to this day and has lost none of its relevance. But it's not just the design that lasts, the quality is also unparalleled. And that's why we give a 10-year guarantee on the surface.



GUARANTEE  
chrome finish



# 710003/ # 710052

Handtuchhalter  
Towel Rail

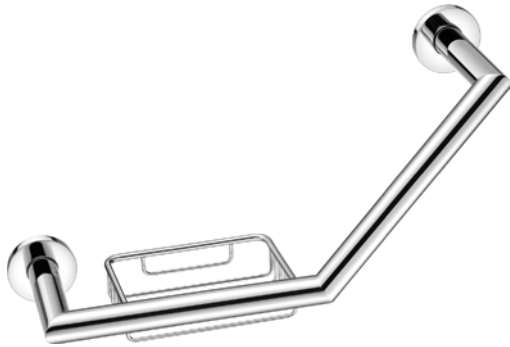
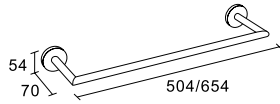

# 710056

Sicherheits-Haltegriff  
mit Seifenkörbchen  
Wechselseitige Montage  
Safety Grab Bar  
with Soap Basket  
Adjusts to left & right  
hand installations

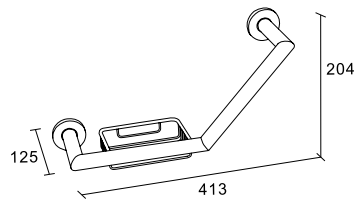

# 710053

Sicherheits-Haltegriff  
Safety Grab Bar

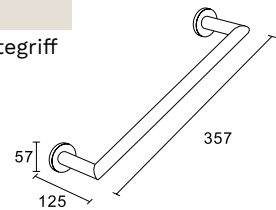

# 710013

Papierrollenhalter  
Toilet Roll Holder

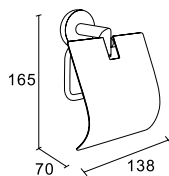

# 710008

Papierrollenhalter  
Toilet Roll Holder

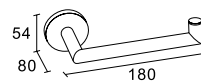

# 710061

Ausführung links  
Left hand mount

# 710009

Reserverollenhalter  
Spare Roll Holder

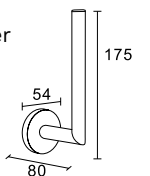

# 710059

Handtuchablage  
Towel Rack

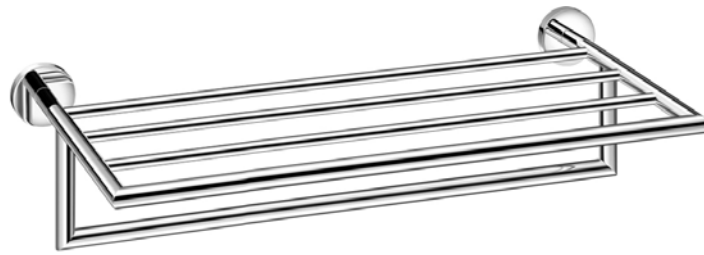
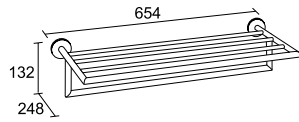

# 710014

Doppel-Haken  
Double Hook

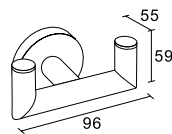

# 710006

Haken  
Hook

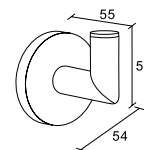

# 710010  
WC-Bürstengarnitur  
Satinieretes Glas  
Toilet Brush Holder  
Iced Glass

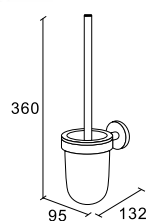

WC-Bürstengarnitur  
Toilet Brush Holder

# 030633

Standmodell  
Free standing

# 030707

Wandmontage  
Wall mounted

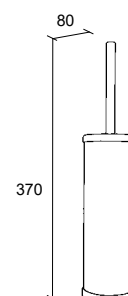



TIMELESS. PURE.

NOW

Ein Design an dem man sich einfach nicht satt sieht. NOW. Der Klassiker unter den Accessoire-Serien - dank klarer Formensprache und zeitloser Schönheit.

A design that you simply can't get enough of. NOW. The classic among the accessory lines - thanks to its pure design language and timeless beauty.





# 740001

Handtuchablage  
Towel Rack

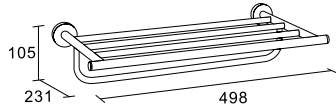

# 740008

Papierrollenhalter  
Toilet Roll Holder

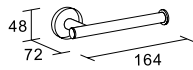

# 740010

Glashalter  
Satinierteres Glas  
Glass Holder  
Iced Glass

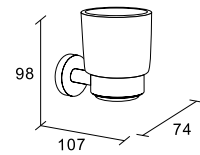

# 740065

Ausführung links  
Left hand mount



# 740006

Papierrollenhalter  
Toilet Roll Holder

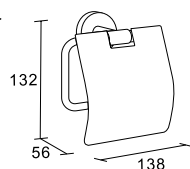

# 740007

Papierrollenhalter  
Toilet Roll Holder

# 740066

Ausführung links  
Left hand mount

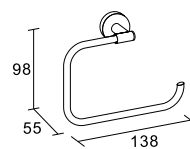

# 740017

Reserverollenhalter  
Spare Roll Holder

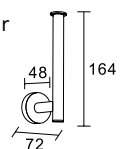

Handtuchhalter  
Towel Rail

# 740002

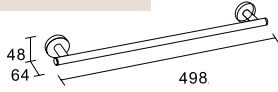

# 740013

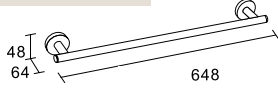

# 740004

Doppel-Haken  
Double Hook

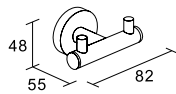

# 740016

Haken  
Hook

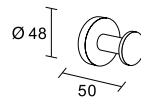

# 030527

Haken  
Hook

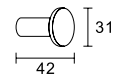

# 740009

WC-Bürstengarnitur  
Satinieretes Glas  
Toilet Brush Holder  
Iced Glass

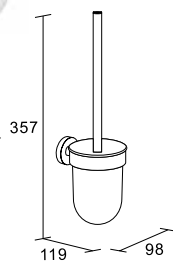

# 740018

WC-Bürstengarnitur.  
Standmodell  
Toilet Brush Holder.  
Free standing

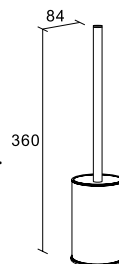

# 030768

WC-Bürstengarnitur.  
Wandmontage  
Toilet Brush Holder.  
Wall mounted

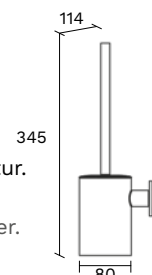

NEW

TIMELESS. BLACK.

# NEXXUS

Das zeitlos schlichte Design unserer NOW-Serie, bekommt mit NEXXUS ihr matt schwarzes Pendant. Ein schöner Kontrast zu hellen Fliesen und Wänden. Damit man auf seine schwarzen Lieblinge nicht unnötig lang warten muss, sind alle Produkte der schwarzen NEXXUS-Serie natürlich auch ab Lager verfügbar.

The timelessly pure design of our NOW series gets its matt black counterpart with NEXXUS. A beautiful contrast to light-colored tiles and walls. To avoid having to wait unnecessarily long for your black favourites, all products in the black NEXXUS series are of course also available from stock.



GUARANTEE  
powder coating

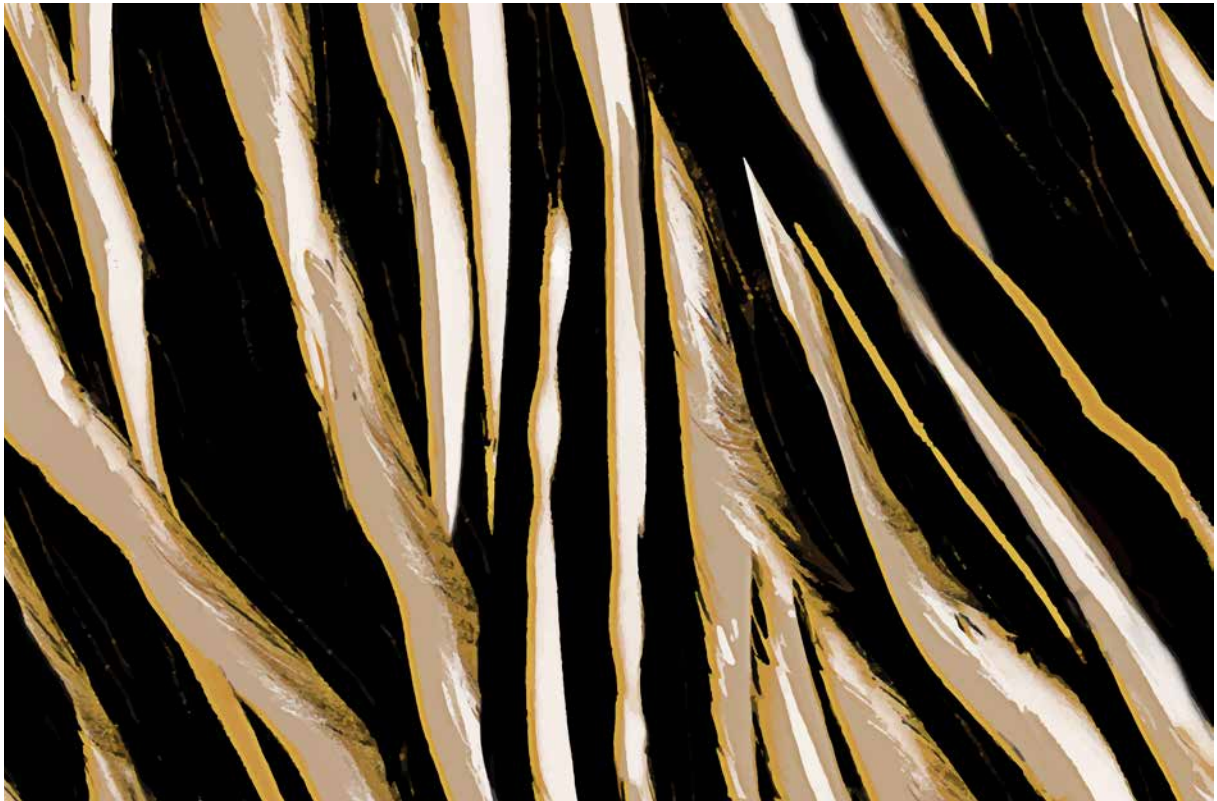





# 740045

Haken  
Hook

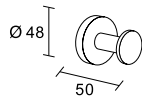

# 740050

Doppel-Haken  
Double Hook

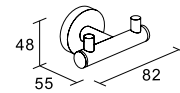

# 740047/ 740054

Handtuchhalter  
Towel Rail

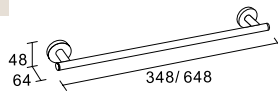

# 030708

WC-Bürstengarnitur  
Wandmontage  
Toilet Brush Holder  
Wall Mounted

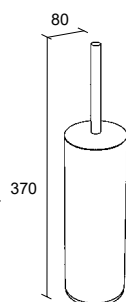

# 030768.102

WC-Bürstengarnitur  
Wandmontage  
Toilet Brush Holder.  
Wall mounted

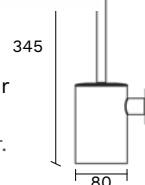

# 740044

WC-Bürstengarnitur  
Satinieretes Glas  
Toilet Brush Holder  
Iced Glass

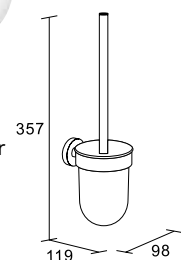



# 740053

Seifenhalter  
Satinieretes Glas  
Soap Dish  
Iced Glass

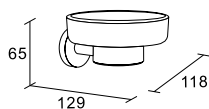

# 740052

Glashalter  
Satinieretes Glas  
Glass Holder  
Iced Glass

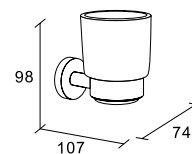

# 740038

Papierrollenhalter  
Toilet Roll Holder

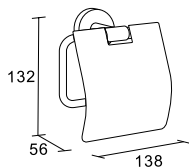

# 740042

Papierrollenhalter  
Toilet Roll Holder

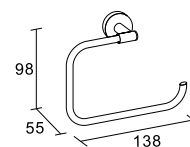

# 740046

Reserverollenhalter  
Spare Roll Holder

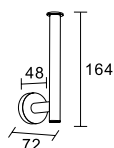

# 740043

Papierrollenhalter  
Toilet Roll Holder

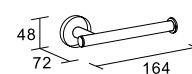

MATCHES. EVERYTHING.

# COMPLEMENTARY

Die Visitenkarte Ihres Hauses! Das gewisse Etwas, die Liebe zum Detail - unterscheidet Ihr Hotel von anderen.

The small details that set your hotel apart from others.







SUSTAINABLE. INNOVATIVE.

## FLAKY & PURITY

Als Spezialist für Hotelausstattung setzt ALISEO 2025 mit FLAKY einen neuen Meilenstein. Die erste Seifenmühle, die speziell auf die Anforderungen der Hotellerie zugeschnitten ist – funktional, stilvoll und nachhaltig zugleich. Hinter dem charmanten Namen steckt eine echte Revolution: gigantische Einsparungen bei Plastik, Emissionen und Rohstoffen. Die PURITY Seife und das Shampoo aus dem Schwarzwald entsprechen Naturkosmetikstandards und machen das Hotelbad grüner als je zuvor.

As a specialist in hotel furnishings, ALISEO 2025 is setting a new milestone with FLAKY. The first soap grinder that is specially designed to meet the requirements of the hotel industry - functional, stylish and sustainable at the same time. Behind the charming name lies a true revolution: huge savings in plastic, emissions and resources. The PURITY soap and shampoo from the Black Forest meet natural cosmetics standards and make the hotel bathroom greener than ever before.

Zur Wandmontage  
 mit Schrauben und Dübel oder 3M-Klebeband  
 Inklusive Wandhalterung und Schlüssel zum Öffnen  
 Inklusive Schrauben, Dübel und 3M-Klebeband  
 Mit Füllstandanzeige  
 Patentiertes Schnellwechselsystem  
 Geeignet für den Einsatz am Waschbecken & in der Dusche  
 Nachfüllbar mit PURITY Seife  
 Optional mit zusätzlicher Utensilienablage  
 100% recyclingfähig  
 Material: Polyamid (PA6) + Aluminium

For wall mounting  
 With screws and anchors or 3M adhesive strips  
 Including wall mount and key for opening  
 Including screws, anchors and 3M adhesive strips  
 With fill level indicator  
 Patented quick-change system  
 Suitable for use at the sink and in the shower  
 Refillable with PURITY soap  
 Optionally with additional shelf  
 100% recyclable  
 Material: Polyamid (PA6) + Aluminium



Gigantische Einsparungen bei Plastik, Emissionen und Rohstoffen  
Huge savings in plastic, emissions and raw materials



VERFÜGBARE VARIANTEN. AVAILABLE VARIANTS

#		FARBE. COLOR	B X H X T. W X H X D
030754	FLAKY einzeln. single	schwarz. black	86 x 107 x 115
030756	mit Utensilienablage. with shelf	schwarz. black	239 x 107 x 115
030761	mit 24x Handseife. with 24x hand soap	schwarz. black	86 x 107 x 115
030762	mit 24x Haar-/Körperseife. with 24x hair/body soap	schwarz. black	86 x 107 x 115

# 030759  
 PURITY Handseife  
 Farbe moos  
 42 x 65 x 42 (B x H x T)  
 12 Stück pro Verpackungseinheit,  
 nicht für den Einzelverkauf  
 PURITY hand soap  
 Color moss  
 42 x 65 x 42 (W x H x D)  
 12 pieces per packing unit,  
 not for individual sale

# 030757  
 PURITY Haar- und Körperseife  
 Farbe schnee  
 42 x 65 x 42 (B x H x T)  
 12 Stück pro Verpackungseinheit,  
 nicht für den Einzelverkauf  
 PURITY hair and body soap  
 Color snow  
 42 x 65 x 42 (W x H x D)  
 12 pieces per packing unit,  
 not for individual sale



030754



030756



030761



030762



030759



030757

## COMPLEMENTARY



Seifenablage  
Zum Kleben - schnelle Wandmontage  
Soap dish  
For gluing - quick mounting

# 030753

Edelstahl, verchromt  
Stainless steel, chrome

# 030753.102

Edelstahl, schwarz matt  
Stainless steel, black matt  
mit Pulverbeschichtung. with powder coating

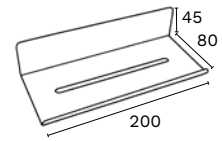

Seifenablage  
Zum Schrauben  
Soap dish  
For drilling

# 030763.102

Edelstahl, verchromt  
Stainless steel, chrome  
mit Pulverbeschichtung. with powder coating

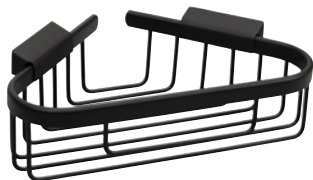

# 030706

Eckseifenkörbchen  
Messing mit  
Pulverbeschichtung  
Corner Soap basket  
Brass with powder coating

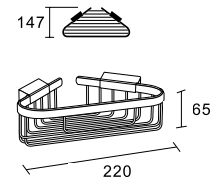

# 030466

Eckseifenkörbchen  
Messing, verchromt  
Corner Soap Basket  
Brass, chrome finish

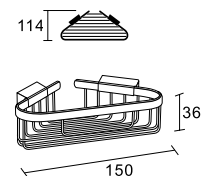

# 030509

Eckseifenkörbchen  
Messing, verchromt  
Corner Soap Basket  
Brass, chrome finish

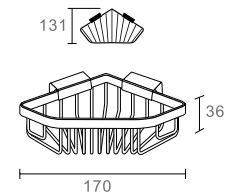

# 030533

Eck-Ablage  
Messing, verchromt  
Corner Shelf  
Brass, chrome finish

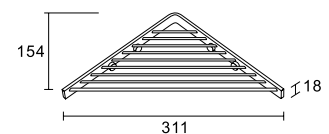

# 030463

Seifenkörbchen  
Messing, verchromt  
Soap Basket  
Brass, chrome finish

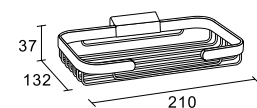

# 030416

Wäscheleine  
Messing, verchromt  
Clothes Line  
Brass, chrome finish

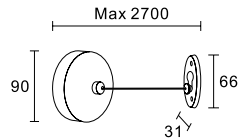

Hygienebaghalter  
Sanitary Bag Dispenser

# 030628

Kunststoff, verchromt  
Sanitary Bag Dispenser

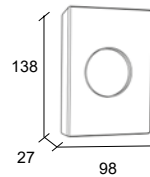

# 030662

Kunststoff, schwarz matt  
Plastic, black matt

Kosmetiktuchspender zum Einbau  
Einbaumaße: 264 x 130 x 76 mm  
Built-in Tissue Dispenser  
Built-in dimensions: 264 x 130 x 76 mm

# 030449

Messing, verchromt  
Brass, chrome finish

# 030710

Messing, schwarz matt  
Brass, black matt

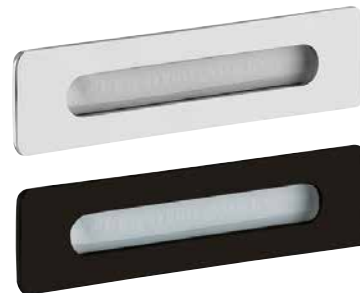
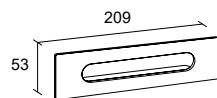

Kosmetiktuchspender CUBE  
Tissue Dispenser CUBE

# 030506

Kunststoff, verchromt  
Plastic, chrome finish

# 030661

Kunststoff, schwarz matt  
Plastic, black matt

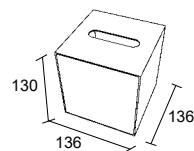

Kosmetiktuchspender  
Tissue Dispenser

# 030724

ABS-Kunststoff, verchromt  
ABS-plastic, chrome finish

# 030771

Kunststoff, schwarz matt  
Plastic, black matt

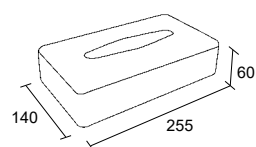

DURABLE. FUNCTIONAL. EASY.

# HYGIENE EIMER. BINS

Modelle überzeugen durch erstklassige Verarbeitung, langlebige Materialien und funktionales Design. Robust und pflegeleicht, bieten sie eine hygienische und stilvolle Lösung für den täglichen Hotelbetrieb.

Models impress with their first-class workmanship, durable materials and functional design. Robust and easy to clean, they offer a hygienic and stylish solution for everyday hotel operations.



silent soft close system

## ABSENKAUTOMATIK. SILENT SOFT CLOSE.

Ein patentiertes Hydrauliksystem ermöglicht das geräuscharme Absenken des Deckels. Das verstärkte Pedal verteilt die Kraft gleichmäßig. Ein solides System, das über 100.000 Betätigungen ermöglicht.

Intelligent soft-close function controlled by a patented hydraulic lid system. Rib-reinforced steel pedal distributes foot force equally. Extending service life in upwards of 100,000 steps.



fingerprint resistant

## ANTI-FINGERABDRUCK. FINGERPRINT RESISTANT.

Hochwertiger Edelstahl mit spezieller Anti-Fingerabdruck-Beschichtung. Die Oberfläche bleibt frei von Abdrücken und ist einfacher zu reinigen.

High-quality stainless steel with fingerprint resistant coating keeps the bin clean and easy to maintain.



removable inner plastic bin

## HERAUSNEHMBARER KUNSTSTOFFEINSATZ. REMOVABLE INNER BIN.

Herausnehmbarer, solider Inneneimer. Verstärktes Gelenk mit Tragegriff

Durable lift-out inner bucket catches messy drips. Strong back handle



plastic bag fixer

## BEUTELFIXIERUNG. PLASTIC BAG FIXER.

Plastikbeutel lassen sich mittels einer Befestigungsöse am Inneneimer problemlos befestigen.

Plastic bag fixer helps secure the bag with no visible excess, keeping the bags neat and orderly.



solid base with silicone ring

## SICHERER STAND. SOLID BASE.

Kunststoffboden mit rutschfesten, oberflächen-schonenden Pads geben dem Eimer Stabilität.

Plastic bottom, non-skid base and insulated pads are gentle on the floor and keeps the bin steady.



stay open design

## STAY-OPEN-FUNKTION. STAY OPEN DESIGN.

Komfortable Deckelverankerung bei längerem Gebrauch.

Lid lock-out for convenient longer term usage.



open bin

## OHNE ABDECKUNG. OPEN BIN.

Offener Eimer für mühelose Abfallbeseitigung.

Open mouth design for effortless trash discard.



WASTE

SEPARATION

# LONDONER BIN

## LONDONER ABFALLBEHÄLTER

2 herausnehmbare Metalleinsätze  
Mit Kunstleder-Ummantelung  
Boden mit rutschfesten, bodenschonenden Pads

## LONDONER WASTE BIN

2 removable metal inner bins  
With faux leather casing  
Bottom with silicone pads for a solid base  
and surface protection

# 190067	taupe	2 x 6 L
	taupe	2 x 6 L
# 190093	schwarz	2 x 6 L
	black	2 x 6 L

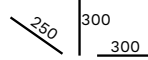

open bin



solid base with  
silicone ring



removable  
inner bin



190067  
190093

## LONDONER ABFALLBEHÄLTER

1 herausnehmbarer Metalleinsatz  
Mit Kunstleder-Ummantelung  
Boden mit rutschfesten, bodenschonenden Pads

## LONDONER WASTE BIN

1 removable metal inner bin  
With faux leather casing  
Bottom with silicone pads for a solid base  
and surface protection

# 190026	taupe	10 L
	taupe	10 L
# 190094	schwarz	10 L
	black	10 L
# 520694	separater Einsatz	
	waste bin separator	

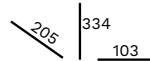

## LONDONER ABFALLBEHÄLTER EINSATZ

Optionaler separater Einsatz  
Passend für # 190026 & # 190094

## LONDONER WASTE BIN SEPARATOR

Optional waste bin separator  
Fits # 190026 & # 190094



open bin



solid base with  
silicone ring



removable  
inner bin



190026  
190094



520694

## LONDONER ABFALLBEHÄLTER

Metall mit abnehmbarer Kunstleder-Ummantelung  
Mit Silikonring für sicheren Stand und Schonung der Oberfläche

## LONDONER WASTE BIN

Metal with removable faux leather casing  
With silicone ring for a solid base and surface protection

# 190025	taupe	9 L
	taupe	9 L
# 190055	schwarz	9 L
	black	9 L



225  
270



## LONDONER ABFALLBEHÄLTER EINSATZ

Optionaler separater Einsatz  
Passend für # 190025 & # 190055  
Metall

## LONDONER WASTE BIN SEPARATOR

Optional waste bin separator  
Fits # 190025 & # 190055  
Metal

# 520732	schwarz	4 L	103 x 243 x 206 mm
	black	4 L	103 x 243 x 206 mm



open bin



solid base with  
silicone ring



removable  
inner bin



190025  
190055



520732

# BATHROOM BIN

## PRESTIGE

Abfallbehälter

3 herausnehmbare Kunststoffeinsätze

Transparente Anti-Fingerabdruck-Lackierung

Mit Silikonring für sicheren Stand und Schonung der

Oberfläche

Edelstahl

Waste Bin

3 removable inner plastic bins

Transparent fingerprint resistant coating

With silicon ring for solid base and surface protection

Stainless steel



# 030720

chrom gebürstet  
brushed chrome

3 x 3,5 L  
3 x 3,5 L

250  
310



open bin



fingerprint resistant



removable  
inner plastic bin



solid base with  
silicone ring



030720

## ABFALLBEHÄLTER

3 herausnehmbare Kunststoffeinsätze

Mit Silikonring für sicheren Stand und Schonung der  
Oberfläche

Innentonne: Polypropylen (PP)

Außentonne: Stahl mit Pulverbeschichtung

Inkl. Recycling Labels zur Kennzeichnung

WASTE BIN

3 removable inner plastic bins

With silicon ring for solid base and surface protection

Inner bin: Polypropylen (PP)

Outer bin: steel with powder coating

Includes recycling labels for identification



# 030765.102

schwarz matt  
black matt

3 x 3 L  
3 x 3 L

236  
307



removable  
inner plastic bin



solid base with  
silicone ring



030765.102

NEW

HYGIENEEMER

Wandmontage  
 Herausnehmbarer Kunststoffeinsatz  
 Deckel mit Absenk-Automatik  
 Transparente Anti-Fingerabdruck-Lackierung  
 Edelstahl

WASTE BIN

Wall mounting  
 Removable inner plastic bin  
 Lid with silent soft close system  
 Transparent fingerprint resistant coating  
 Stainless steel



# 030764	chrom poliert	3 L
	polished chrome	3 L

170 | 252



silent soft close system



fingerprint resistant



removable inner plastic bin



030764

ABFALLBEHÄLTER

Abnehmbarer Ring  
 Feuerfest  
 Mit Silikonring für sicheren Stand und Schonung der Oberfläche  
 Metall

WASTE BIN

Removable lid  
 Fire-proof  
 With silicone ring for a solid base and surface protection  
 Metal

SAFETY BIN



# 030627	schwarz	13 L
	black	13 L

240 | 300



fire proof



open bin



solid base with silicone ring



030627

# BATHROOM BIN

## PRESTIGE

Hygieneeimer  
 Herausnehmbarer Kunststoffeinsatz  
 Deckel mit Absenk-Automatik  
 Transparente Anti-Fingerabdruck-Lackierung  
 Abfallbeutelbefixierung  
 Kunststoffboden mit rutschfesten, bodenschonenden Pads  
 Edelstahl

Step Bin  
 Removable plastic inner bin  
 Lid with silent soft close system  
 Transparent fingerprint resistant coating  
 Waste bag fixer  
 Plastic bottom with silicone pads for a solid base and surface protection  
 Stainless steel



# 030654	chrom gebürstet	3 L
	brushed chrome	3 L



# 030655	chrom gebürstet	5 L
	brushed chrome	5 L



# 030691	schwarz	5 L
	black	5 L



# 030692	schwarz	3 L
	black	3 L



silent soft close system



fingerprint resistant



removable inner bin



plastic bag fixer



solid base with silicone ring



NU finishes



030654  
030655



030692  
030691

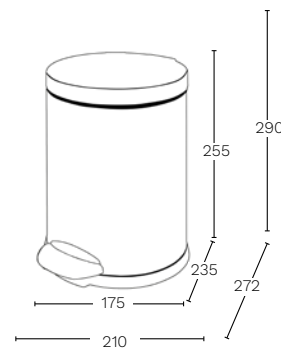

# 030769	weiß matt	3 L
	white matt	3 L

**PRESTIGE**

- Hygieneeimer
- Herausnehmbarer Kunststoffeinsatz
- Deckel mit Absenk-Automatik
- Transparente Anti-Fingerabdruck-Lackierung
- Abfallbeutelbefixierung
- Kunststoffboden mit rutschfesten, bodenschonenden Pads
- Edelstahl
- Step Bin
- Removable inner plastic bin
- Lid with silent soft close system
- Transparent fingerprint resistant coating
- Waste bag fixer
- Plastic bottom with silicone pads for a solid base and surface protection
- Stainless steel

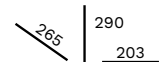

# 030657	chrom gebürstet	5 L
	brushed chrome	5 L



silent soft close system



fingerprint resistant



removable inner plastic bin



plastic bag fixer



solid base with silicone ring



030657



030769

HIGH QUALITY. PRECISE. SECURE.

## WAAGEN. SCALES

Hochwertige Personenwaagen mit präziser Messtechnik, langlebigem Design und sicherer Standfläche – ideal für anspruchsvolle Hotelbäder.

High-quality bathroom scales with precise measurement technology, durable design and secure base - ideal for demanding hotel bathrooms.



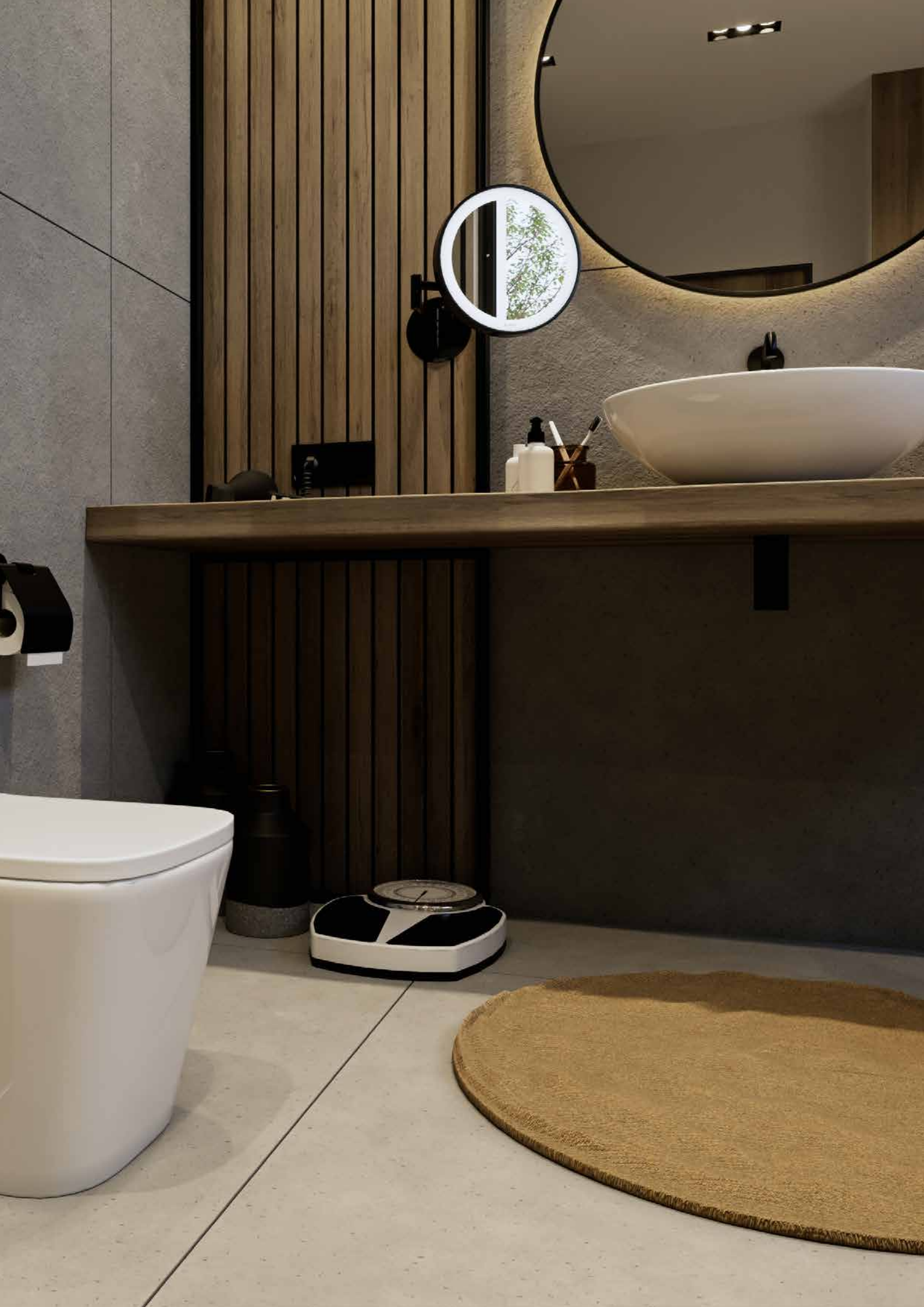

# BATHROOM SCALE

## NEVIS

Elektronisch  
 6 mm starkes Sicherheitsglas  
 Tragkraft max. 150 kg  
 Teilung 100 g  
 Umschaltbar auf Pfund (lbs)  
 Step-on-Funktion  
 4 Gewichtssensoren  
 Automatische Abschaltung  
 3 x 1,5V AAA-Batterien  
 Material: ABS Kunststoff

Electronic  
 6 mm thick safety glass  
 Capacity max. 150 kg  
 Graduation 100 g  
 Switchable to pounds (lbs)  
 Step-on technology  
 4 weight sensors  
 Auto-shut-off  
 3 x 1,5V AAA-batteries  
 Material: ABS plastic



# 030626

silber  
 silver

338  330 | 21/35



battery powered



030626



# 030475

glasklar/silber  
 clear/silver

300  300 | 35



battery powered



030475

## FUTURA

Elektronisch  
 6 mm starkes Sicherheitsglas  
 Tragkraft max. 200 kg  
 Teilung 100 g  
 Umschaltbar auf Pfund (lbs)  
 Step-on-Funktion  
 4 Gewichtssensoren  
 Automatische Abschaltung  
 1 x 3V Lithium Batterie, CR2032  
 Material: korrosionsgeschützte Epoxid-Kunststoffbeschichtung

Electronic  
 6 mm thick safety glass  
 Capacity max. 200 kg  
 Graduation 100 g  
 Switchable to pounds (lbs)  
 Step-on technology  
 4 weight sensors  
 Auto shut-off  
 1 x 3V lithium battery, CR2032  
 Material: corrosion resistant epoxy-plastic coating

BOHEMIA

Mechanisch - extra groß  
 Großzügige Trittfläche  
 Verzerrungsfreie Glasscheibe  
 Solide Konstruktion  
 Tragkraft max. 160 kg  
 Teilung 500 g  
 Anzeige in Kilo und Pfund (lbs)  
 Material: Metall, korrosions-  
 geschützte Emailbeschichtung

Mechanical - extra large  
 Comfortable platform  
 Fog-free glass lens  
 Durable construction  
 Capacity max. 160 kg  
 Graduation 500 g  
 Display in kg and pound (lbs)  
 Material: metal, corrosion  
 resistant enamelled coating



# 030490

schwarz/chrom  
 black/chrome

435  320 | 68



030490



# 030653

weiß/silber  
 white/silver

306  306 | 22

STEP

Elektronisch  
 6 mm starkes Sicherheitsglas  
 Tragkraft max. 180 kg  
 Teilung 100 g  
 Umschaltbar auf Pfund (lbs)  
 Step-on-Funktion  
 4 Gewichtssensoren  
 Automatische Abschaltung  
 1 x 3V Lithium Batterie, CR2032  
 Material: ABS Kunststoff

Electronic  
 6 mm thick safety glass  
 Capacity max. 180 kg  
 Graduation 100 g  
 Switchable to pounds (lbs)  
 Step-on technology  
 4 weight sensors  
 Auto-shut-off  
 1 x 3V lithium battery, CR2032  
 Material: ABS plastic



battery powered



030653





G Ä S T E Z I M M E R  
G U E S T R O O M



EXCEPTIONALLY. COLORFUL.

## LONDONER COLORLINE

Mit der LONDONER **COLOR LINE** hebt ALISEO Individualisierung auf ein neues Level. Die luxuriösen Kunstleder-Accessoires können auch in über 60 Farbtönen individuell angepasst werden. Und wenn das nicht reicht, versuchen wir auch gerne darüber hinaus individuelle Töne zu treffen. So lassen sich Designkonzepte konsequent bis ins Detail umsetzen – perfekt abgestimmt auf das Interieur und die Markenidentität eines Hotels. Hochwertige Materialien, präzise Verarbeitung und langlebige Qualität machen die LONDONER **COLOR LINE** zur idealen Wahl für anspruchsvolle Hoteliers, die ihren Gästen ein stimmiges, stilvolles Ambiente bieten möchten.

With the LONDONER **COLOR LINE**, ALISEO takes individualization to a new level. The luxurious faux leather accessories can also be customized in over 60 shades. And if that's not enough, we are also happy to try and match individual tones beyond that. In this way, design concepts can be consistently implemented down to the last detail - perfectly coordinated with the interior and the brand identity of a hotel. High-quality materials, precise workmanship and long-lasting quality make LONDONER **COLOR LINE** the ideal choice for discerning hoteliers who want to offer their guests a harmonious, stylish ambience.



COLOR LINE



other colors?  
contact us!





## UNBEGRENZTE FARBVIELFALT UNLIMITED VARIETY OF COLORS

Wer eine aristokratische Atmosphäre schätzt, wird unsere beiden Standardfarben schwarz und taupe lieben. Denn sie sind in ihrer Dezent nicht zu übertreffen. Wessen Herz beim Gedanken an eine schöne Farbe jedoch höher schlägt, liegt mit der LONDONER COLORLINE genau richtig. Nicht weniger edel, aber um einen Farbtupfer reicher. Die Standardfarbauswahl umfasst bereits 60 fein abgestimmte Töne. Da ist bestimmt der passende dabei. Sollten Sie dennoch einen individuellen Farbton wünschen, bieten wir Ihnen auch diesen gerne an. Denn das Leben ist bunt...

Anyone who appreciates an aristocratic atmosphere will love our two standard colors black and taupe. Because they can't be beaten in their subtlety. However, if your heart beats faster at the thought of a beautiful color, the LONDONER COLORLINE is just right for you. No less elegant, but with a splash of color. The standard color selection already includes 60 finely coordinated shades. You are sure to find the right one. However, if you would like an individual shade, we will be happy to offer you this too. Because life is colorful...

## VERFÜGBARKEITEN AVAILABILITIES

Alle Artikel der LONDONER Leder-Accessoires sind in der Regel in den klassischen Farben schwarz und taupe bei uns vorrätig und sofort versandbereit. Die 60 Standardfarben der LONDONER COLORLINE produzieren wir gerne für Sie auf Auftrag. Bitte beachten Sie in diesem Fall die Mindestbestellmenge von 30 Stück je Farbe.

All items in the LONDONER leather accessories range are generally available from stock in the classic colors black and taupe and can be shipped immediately. We are happy to produce the 60 standard colors of the LONDONER COLORLINE for you to order. In this case, please note the minimum order quantity of 30 pieces per color.

## AM ANFANG STEHT DIE VISION IT ALL STARTS WITH A VISION



Individuelle Farben und Oberflächen ermöglichen die perfekte Umsetzung Ihrer Vision. Denn es sind Details wie diese, die den Unterschied machen. Wir haben mit ALISEO ATELIER einen Bereich geschaffen, in dem wir grenzenlose Farbvielfalt ermöglichen.

Stöbern Sie im ATELIER Katalog oder entdecken Sie noch mehr Inspiration online.

Individual colors and surfaces enable the perfect implementation of your vision. Because it's details like these that make the difference. With ALISEO ATELIER, we have created an area in which we enable limitless color variety.

Have a look through the ATELIER catalog or discover even more inspiration online.





LEATHER. ACCESSORIES.

## LONDONER

Londoner Leder-Accessoires vereinen zeitlose Eleganz mit höchster Handwerkskunst. Jedes Detail ist sorgfältig verarbeitet, um Hotels eine stilvolle und langlebige Ausstattung zu bieten. Ob Schreibtischunterlagen, Rechnungsmappen, Zeitschriftenständer oder Papierkörbe – die edle Optik und angenehme Haptik machen diese Kollektion zu einem besonderen Highlight in jedem Hotelzimmer. Hochwertiges Kunstleder in den klassischen Farbtönen schwarz und taupe sorgt für eine luxuriöse Atmosphäre und eine pflegeleichte, strapazierfähige Oberfläche.

Londoner leather accessories combine timeless elegance with the highest level of craftsmanship. Every detail is carefully crafted to provide hotels with stylish and durable furnishings. Whether desk pads, invoice folders, magazine holder or wastepaper baskets – the elegant look and pleasant feel make this collection a special highlight in any hotel room. High-quality faux leather in the classic shades of black and taupe creates a luxurious atmosphere and an easy-care, hard-wearing surface.



taupe

Hochwertiges Kunstleder im klassischen Farbton taupe  
Faux leather in the classic of taupe



black

Hochwertiges Kunstleder im klassischen Farbton schwarz  
Faux leather in the classic shades of black



construction

Der Aufbau: Alle LONDONER Lederaccessoires werden in einer Sandwich-Konstruktion gefertigt. Die Stabilität im Inneren liefert eine dünne MDF-Platte. Auf der Aussenseite erhält diese durch eine weiche Kartonage ihre unverwechselbar federnde Griffigkeit. Aussen und innen bildet feinstes Kunstleder (PU) optisch und haptisch den perfekten Abschluss. Alle Komponenten werden mittels eines ungiftigen, geruchlosen Klebers aufeinander kaschiert.

The construction: All LONDONER leather accessories are manufactured in a sandwich construction. A thin MDF board provides the stability on the inside. On the outside, soft cardboard gives it its unmistakably springy feel. The finest artificial leather (PU) on the outside and inside provides the perfect visual and haptic finish. All components are joined using a non-toxic, odorless adhesive.

OUTSIDE

LEDER / LEATHER

KARTON / CARTON

MDF / MDF

LEDER / LEATHER

INSIDE



fine stitching

Dank handgearbeiteter Ziernähte eine Klasse für sich... und trotzdem langlebig, wasserabweisend und stabil.

A class of its own thanks to handcrafted decorative stitching... and yet durable, water-repellent and stable.



rounded corners

Abgerundete Kanten bewusst ohne Ziernähte verleihen moderne Eleganz.

Rounded corners deliberately without decorative stitching create a modern elegance.



stain removal

Fleckenentfernung: Alle Artikel aus der LONDONER Kollektion sind von sehr guter Qualität und bedürfen nur eines geringen Pflegeaufwandes. Bei Flecken oder Verunreinigungen reicht meistens ein leicht feuchtes (Microfaser-)Tuch aus. Bitte achten Sie dabei auf eine möglichst geringe Menge Wasser im Tuch. Verzichten Sie unbedingt auf aggressive Reiniger oder Chemikalien auf Säurebasis. Eine milde Seife ist völlig ausreichend. Nach der Reinigung nehmen Sie überschüssige Seifenreste mit einem feuchten Tuch ab. Um zurückbleibende Schlieren und Flecken zu vermeiden, mit einem sauberen Tuch trockenreiben.

Stain removal: All items from the LONDONER collection are of very good quality and require very little care. A slightly damp (microfiber) cloth is usually sufficient. Please ensure that the amount of water in the cloth is as small as possible. Do not use aggressive cleaning agents or acid-based chemicals. A mild soap is completely sufficient. After cleaning, remove excess soap residue with a damp cloth. To avoid leaving streaks and stains, wipe dry with a clean cloth.



COLOR LINE

Mit Londoner Colorline erhalten Sie die Londoner Leder-Accessoires in Ihrer Wunschfarbe. Die Standardfarbauswahl umfasst bereits 60 fein abgestimmte Töne. Da ist bestimmt der passende dabei. Sollten Sie dennoch einen individuellen Farbton wünschen, bieten wir Ihnen diesen gerne ebenfalls an.

Londoner Colorline offers Londoner leather accessories in the color of your choice. The standard color selection already offers 60 perfectly harmonized shades. You are certain of finding the right one. However, if you prefer a specific color, we can certainly assist you.



other colors?  
contact us!

Flexibilität ist das halbe Leben. Und weil wir das wissen, wollen wir immer versuchen Ihre Wünsche und Ideen wahrwerden zu lassen. Die passende Farbe oder Oberfläche ist nicht dabei? Dann kontaktieren Sie uns!

Flexibility is half the battle. And because we know this, we always try to make your wishes and ideas come true. Can't find the right color or surface? Then contact us!

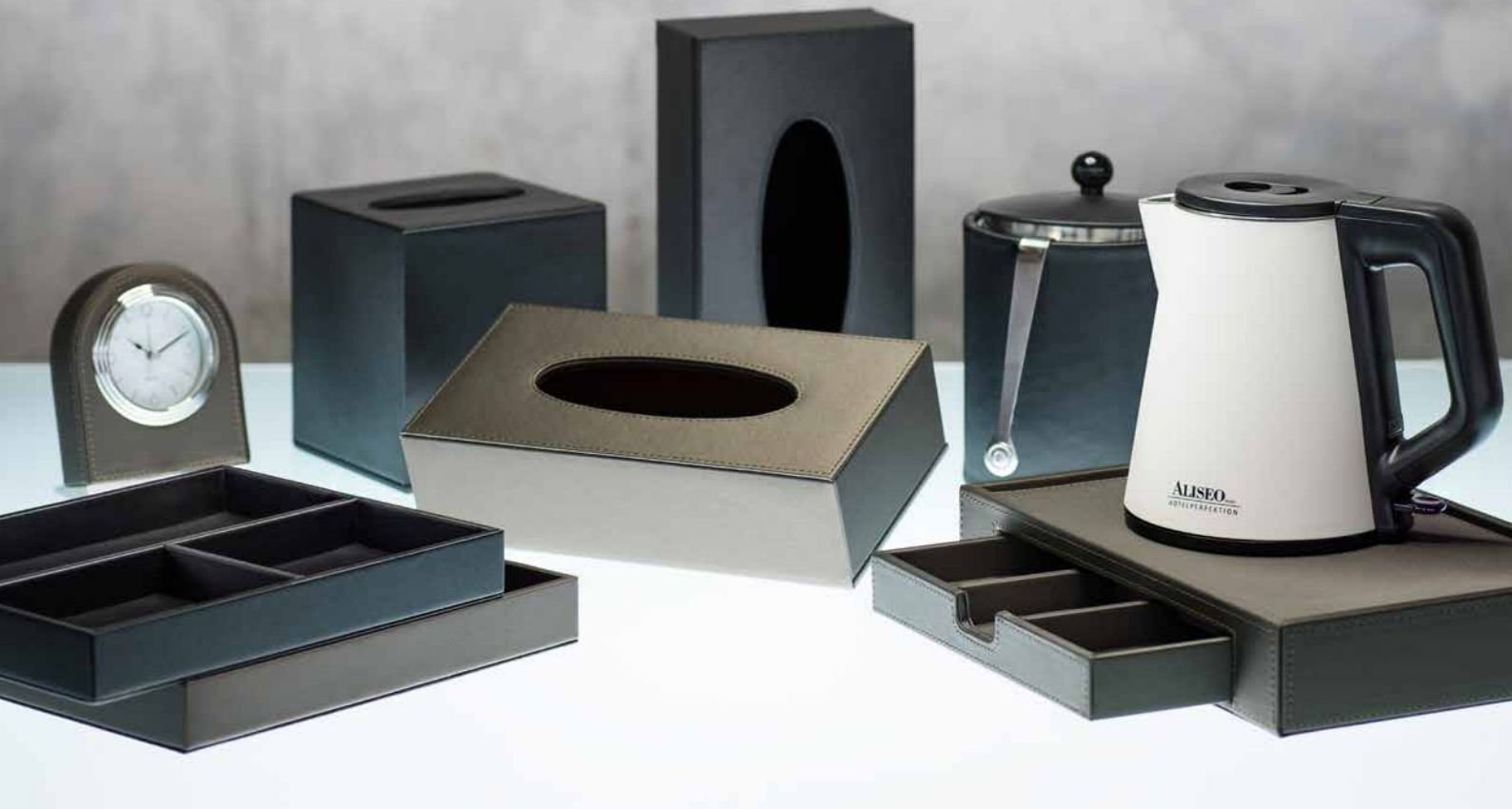

EXCEPTIONALLY. SIMPLE.

## LONDONER CLASSIC LINE

Jedes Stück der LONDONER CLASSIC LINE ist eine Hommage an zeitlose Eleganz. Feinstes Kunstleder, samtweiche satinierte Haptik und handgearbeitete Ziernähte verschmelzen zu Accessoires, die nicht nur funktional sind, sondern Räume veredeln. In Schwarz oder Taupe gehalten, fügen sie sich wie selbstverständlich in luxuriöse Interiors ein – dezent, aber mit der Aura britischer Noblesse. Für alle, die das Besondere suchen – auch auf Maß.

Each piece in the LONDONER CLASSIC LINE is a tribute to timeless elegance. The finest faux leather, velvety-soft satin feel and hand-finished decorative stitching merge to create accessories that are not only functional, but also enhance rooms. Available in black or taupe, they blend naturally into luxurious interiors – discreet, but with an aura of British noblesse. For all those who are looking for something special – also made to measure



fine stitching



black



taupe



COLOR LINE



other colors?  
contact us!



- # 190126 - taupe
- # 190127 - schwarz. black

Tablett groß  
mit Schubfach  
Tray big  
with drawer

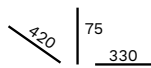

IN  
2 GRÖSSEN  
—  
IN  
2 SIZES

- # 190057 - taupe
- # 190084 - schwarz. black

Tablett klein  
mit Schubfach  
Tray small  
with drawer

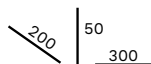



# 190001 - taupe  
# 190068 - schwarz. black

Tablett  
Tray

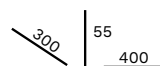

# 190003 - taupe  
# 190070 - schwarz. black

Ablagebehälter  
mit zwei Fächern  
Sachet Box  
with two compartments

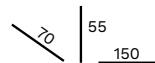

# 190063 - taupe  
# 190089 - schwarz. black

Tablett - Meeting  
Tray - Meeting

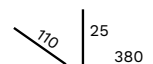



Abgebildet mit Wasserkocher BONJOUR # 170282 und Tassen # 170258.  
Kaffeemaschine & Kapseln sind Dekoration.  
Shown with kettle BONJOUR # 170282 and mugs # 170258.  
Coffee machine & capsules are decoration.



- # 190061 - taupe
- # 190087 - schwarz. black

Tablett  
mit 2 Löchern ø 55 mm für Kabel des  
Wasserkochers  
Tray  
with 2 holes ø 55 mm for cable of water kettle

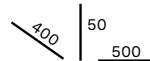

IN  
2 GRÖSSEN  
—  
IN  
2 SIZES



- # 190060 - taupe
- # 190086 - schwarz. black

Tablett  
mit Loch ø 55 mm für Kabel des Wasserkochers  
Tray  
with hole ø 55 mm for cable of water kettle

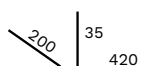



# 190062 - taupe  
# 190088 - schwarz. black

Utensilienbox  
mit 5 Fächern und arretierbarem  
Deckel  
Stationary Box  
with 5 compartments and hinged lid

150 | 40  
350



# 190009 - taupe  
# 190072 - schwarz. black

Utensilienbox  
mit 3 Fächern  
Stationary Box  
with 3 compartments

250 | 30  
250



# 190065 - taupe  
# 190091 - schwarz. black

Kapselbehälter  
mit wendbarer Einlage für 2 oder 4  
Kapseln  
Coffee Capsule Box  
with reversilbe insert for 2 or 4 capsules

120 | 47  
120



# 190059 - taupe  
# 190085 - schwarz. black

Minibar-Tablett  
Minibar Tray

350 | 30  
350



# 190004 - taupe  
 # 190071 - schwarz. black  
 Glas-/Tassenuntersetzer  
 Coaster



# 190006 - taupe  
 # 190051 - schwarz. black  
 Eiswürfelbehälter, 1 Liter  
 mit Deckel und Zange. Edelstahl  
 Ice Cube Container, 1 litre  
 with lid and tongs. Stainless steel

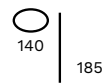

# 190016 - taupe  
 # 190052 - schwarz. black  
 Kosmetiktuchspender  
 mit magnetischer Bodenklappe  
 Tissue Dispenser  
 with magnetic trap at the bottom

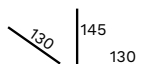

# 190017 - taupe  
 # 190078 - schwarz. black  
 Kosmetiktuchspender  
 mit magnetischer Bodenklappe  
 Tissue Dispenser  
 with magnetic trap at the bottom

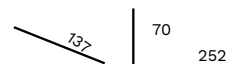



# 190011 - taupe

# 190073 - schwarz. black

Notizblockunterlage  
mit Vertiefungen für Block und Stift  
Note Pad  
with cut-outs for note pad and pen

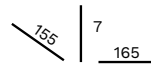

# 190012 - taupe

# 190074 - schwarz. black

Notizblockhalter  
mit magnetischer Klemmschiene  
und Stifthalter  
Note Pad Holder  
with magnetic fold and pen holder

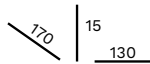

# 190066 - taupe

# 190092 - schwarz. black

Info-Mappe A4  
mit Stifthalter und 4 Fächern  
Service Binder A4  
with pen holder and 4 compartments

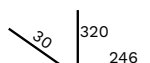



- # 190028 - taupe
- # 190081 - schwarz. black

Info-Mappe A4  
mit 2-Ring-Mechanik  
Service Binder A4  
with two ring clamp

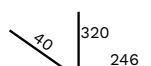

- # 190027 - taupe
- # 190054 - schwarz. black

Info-Mappe A5  
mit 2-Ring-Mechanik  
Service Binder A5  
with two ring clamp

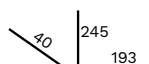

- # 190029 - taupe
- # 190082 - schwarz. black

Rechnungsmappe  
mit magnetischer Klemmschiene  
und Stifthalter  
Bill Presenter  
with magnetic fold and pen holder

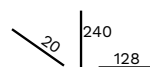

# LONDONER



- # 190030 - taupe
- # 190053 - schwarz. black

Tischauflage  
mit magnetischer Klemmschiene  
Desk pad  
with magnetic fold

405 | 14  
500



- # 190064 - taupe
- # 190090 - schwarz. black

Tischauflage  
Desk pad

380 | 5  
380



- # 190023 - taupe
- # 190080 - schwarz. black

Zeitschriftenständer  
mit zwei Fächern  
Magazine Holder  
with two compartments

100 | 230  
330



- # 190013 - taupe
- # 190075 - schwarz. black

Tischuhr - batteriebetrieben  
mit Weckfunktion und Beleuchtung  
Table Clock - Battery-Powered  
with alarm and lighting

46 | 125  
101

- # 190014 - taupe
- # 190076 - schwarz. black

TV-Mappe mit Fach für Fernbedienung  
und Sichtfenster für Programmliste  
Remote Control Binder  
with compartment for TV channel list

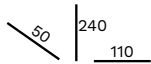

- # 190015 - taupe
- # 190077 - schwarz. black

Fernbedienungsständer  
Remote Control Holder

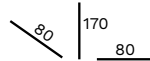

- # 190019 - taupe
- # 190048 - schwarz. black

Kleiderbürste  
Holz mit Aufhängeschlaufe  
Clothes Brush  
wood with hanger 380

- # 190020 - taupe
- # 190049 - schwarz. black

Schuhlöffel  
Holz mit Aufhängeschlaufe  
Shoe Horn  
wood with hanger 380



- # 190214 - schwarz. black

Clutch  
Mit Magnetverschluss  
Passend für VENTO BRUSHLESS, AERO  
BRUSHLESS, STEAMO & AUREA  
Weitere Standardfarben siehe S. 163

With magnetic closure  
Suitable for VENTO BRUSHLESS, AERO  
BRUSHLESS, STEAMO & AUREA  
For more standard colors, see p. 163

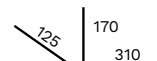

# LONDONER



# 190067 - taupe  
# 190093 - schwarz. black

Abfallbehälter - 2 x 6 L  
Mit zwei herausnehmbaren  
Metalleinsätzen  
103 x 334 x 205 mm  
Waste Bin - 2 x 6 L  
With two removable metal liners  
103 x 334 x 205 mm

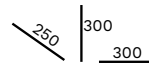

# 190026 - taupe  
# 190094 - schwarz. black

Abfallbehälter - 10 L  
Herausnehmbarer  
Metalleinsatz  
Waste Bin - 10 L  
Removable metal liner

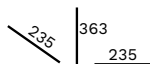

# 190025 - taupe  
# 190055 - schwarz. black

Abfallbehälter - 9 L  
Metall mit abnehmbarer Kunstleder-Ummantelung  
Waste Bin - 9 L  
Metal with removable casing





NEW



Clutch  
 Mit Magnetverschluss  
 Passend für VENTO BRUSHLESS, AERO  
 BRUSHLESS, STEAMO & AUREA  
 With magnetic closure  
 Suitable for VENTO BRUSHLESS, AERO  
 BRUSHLESS, STEAMO & AUREA

- # 190214 - schwarz. black
- # 190214.028 - rose
- # 190214.032 - cream
- # 190214.021 - matcha
- # 190214.055 - berry
- # 190214.058 - ocean
- # 190214.042 - safran
- # 190214.018 - mocha

125 | 170  
 | 310



NEW

EXCEPTIONALLY. MODERN.

## LONDONER MODERN LINE

Jedes Stück der LONDONER MODERN LINE steht für zeitlose Schlichtheit mit modernem Anspruch. Hochwertiges Kunstleder und eine angenehm weiche Oberfläche verleihen den Accessoires eine edle Präsenz, ohne sich in den Vordergrund zu drängen. Ganz bewusst ohne Ziernähte gestaltet, unterstreichen die sanft abgerundeten Ecken und weichen Konturen das reduzierte Design. Die Linie fügt sich harmonisch in jedes anspruchsvolle Interieur. In den Standardartfarben schwarz oder taupe, wirkt die sie puristisch, modern und zugleich außergewöhnlich.

Every piece in the LONDONER MODERN LINE stands for timeless simplicity with a modern twist. High-quality imitation leather and a pleasantly soft surface give the accessories an elegant presence without being overly conspicuous. Deliberately designed without decorative stitching, the gently rounded corners and soft contours emphasize the minimalist design. The line blends harmoniously into any sophisticated interior. In the standard colors black or taupe, it appears purist, modern, and at the same time extraordinary.



rounded corners



black



taupe



COLOR LINE



other colors?  
contact us!



# 190200 - taupe  
 # 191200 - schwarz. black

Tablett  
 Tray

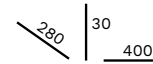

# 190204 - taupe  
 # 191204 - schwarz. black

Kosmetiktuchspender  
 Magnetische Bodenklappe  
 Innenmaß für Nachfüllbox:  
 118 x 135 x 118 mm  
 Tissue Dispenser  
 With magnetic trap at the bottom  
 Inside dimensions refill box:  
 118 x 135 x 118 mm

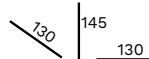

# 190203 - taupe  
 # 191203 - schwarz. black

Kosmetiktuchspender  
 Magnetische Bodenklappe  
 Innenmaß für Nachfüllbox:  
 238 x 58 x 122 mm  
 Tissue Dispenser  
 With magnetic trap at the bottom  
 Inside dimensions refill box:  
 238 x 58 x 122 mm

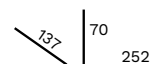



# 190202 - taupe  
 # 191202 - schwarz, black

Tablett - klein  
 Mit Schubfach:  
 218 x 35 x 185 mm  
 Tray - small  
 With drawer:  
 218 x 35 x 185 mm

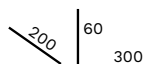

# 190201 - taupe  
 # 191201 - schwarz, black

Tablett - groß  
 Mit Schubfach:  
 225 x 53 x 390 mm  
 Mit Einsatz für Kaffeekapseln  
 Tray - large  
 With drawer:  
 225 x 53 x 390 mm  
 With insert for coffee capsules

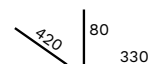





STRIX  
safety controls

### STRIX-CONTROL SAFETY. QUALITY. RELIABILITY.

Unsere Wasserkocher sind mit original Strix-Control ausgestattet – einem der sichersten und langlebigsten Steuerungssysteme weltweit. Die intelligente Technik sorgt für automatische Abschaltung, schützt bei Trockenlauf und reguliert die Temperatur präzise. Für maximale Sicherheit, lange Lebensdauer und entspannten Teeenuss im Hotelzimmer.

Our kettles are equipped with original Strix-Control - one of the safest and most durable control systems in the world. The intelligent technology ensures automatic switch-off, protects against dry running and regulates the temperature precisely. For maximum safety, a long service life and relaxed tea enjoyment in the hotel room.



seamless interior

### NAHTLOSER INNENBEHÄLTER. SEAMLESS INTERIOR. HYGIENE. QUALITY. LONGEVITY.

Der nahtlose Innenraum aus Edelstahl sorgt nicht nur für ein edles Finish, sondern vor allem für maximale Hygiene. Ohne Kanten, Rillen oder Schweißnähte lässt sich der Wasserkocher besonders leicht reinigen – Kalk und Rückstände haben kaum eine Chance. Langlebig, geschmacksneutral und perfekt für den täglichen Einsatz im Hotelzimmer.

The seamless stainless steel interior not only ensures an elegant finish, but above all maximum hygiene. With no edges, grooves or weld seams, the kettle is particularly easy to clean - limescale and residue hardly stand a chance. Durable, tasteless and perfect for daily use in hotel rooms.



0,5 l

### KLEINE FÜLLMENGE. SMALL FILLING QUANTITY. SUSTAINABILITY. EFFICIENCY. GUEST ORIENTATION.

Mit einer Füllmenge von 0,5 Litern ist dieser Wasserkocher ideal auf den Bedarf im Hotelzimmer abgestimmt. Das spart Energie, reduziert Wasserverbrauch und vermeidet unnötigen Reinigungsaufwand. Eine kleine Größe mit großer Wirkung – effizient, nachhaltig und absolut gastfreundlich.

With a capacity of 0.5 liters, this kettle is ideally suited to the needs of hotel rooms. This saves energy, reduces water consumption and avoids unnecessary cleaning. A small size with a big effect - efficient, sustainable and absolutely hospitable.



EFFICIENT. SECURE. STYLISH.

## WASSERKOCHER. WATER KETTLES

Effizient, sicher und stilvoll: Unsere Hotel-Wasserkocher sind speziell für den professionellen Einsatz entwickelt. Neben höchster Qualität und Sicherheitsstandards liegt der Fokus auf Energieeffizienz. Dank kompakter Füllmengen zwischen 0,5 und 0,8 Litern wird nur so viel Wasser erhitzt, wie wirklich benötigt wird – eine smarte Lösung für nachhaltigen Energieverbrauch im Hotel. Modernes Design und langlebige Materialien sorgen für ein hochwertiges Gästeerlebnis.

Simple, elegant and functional. Bonjour is the perfect kettle for the guest room. With an extra small capacity of 0.6 l, it is energy efficient and prevents water wastage. The light cone is reminiscent of the shape of the classic teakettle and stands for warmth and cordiality. The reduction to the essentials inevitably catapults the design into the modern age and makes it a timeless object.

Available in black or ivory.



ELEGANT. RELAXATION.

# BONJOUR

Schlicht, elegant und funktional. BONJOUR ist der perfekte Wasserkocher für das Gästezimmer. Mit einer extra kleinen Füllmenge von 0,6l ist er energieeffizient und Wasserverschwendung wird vorgebeugt. Der leichte Konus ist eine Reminiszenz an die Form des klassischen Teekessels und steht für Wärme und Herzlichkeit. Die Reduzierung auf das Wesentliche katapultiert das Design unweigerlich in die Moderne und macht es zu einem zeitlosen Objekt.

Simple, elegant and functional. BONJOUR is the perfect kettle for the guest room. With an extra small capacity of 0.6 l, it is energy efficient and prevents water wastage. The light cone is reminiscent of the shape of the classic teakettle and stands for warmth and cordiality. The reduction to the essentials inevitably catapults the design into the modern age and makes it a timeless object.

0,6 Liter Füllmenge  
 Integriertes Heizelement  
 Kabellos, 360° drehbar  
 Abschaltautomatik  
 Erweiterter Trockengehschutz  
 Kontrollleuchte  
 STRIX Einheit  
 Deckel mit Sicherheitsverriegelung  
 Doppelwandiges Gehäuse:  
 - innen: Edelstahl  
 - außen: wärmeisolierender Kunststoff  
 Schutzklasse I

0.6 litre capacity  
 Integrated heating element  
 Cordless, 360° rotation  
 Automatic shut-off  
 Boil dry protection  
 Indicator light  
 STRIX unit  
 Lid with safety interlock  
 Double wall construction  
 - inside: stainless steel  
 - outside: insulated cool touch housing  
 Class I

220-240 V, 50/60 Hz 1000 W



STRIX  
safety controls



0,6 l



seamless interior



1000 W



220-240 V



170281



# 170281

schwarz matt  
black matt

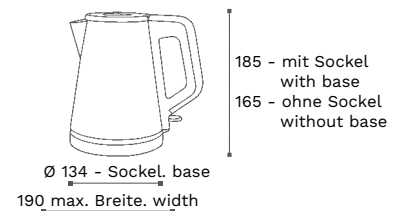

Einfaches Reinigen durch besonders breiten Ausguss und nahtlos gezogenen Edelstahlbehälter  
Doppelwändiges Gehäuse: innen - Edelstahl, außen - wärmeisolierender Kunststoff  
Extra wide mouth and seamless canister improves ease of cleaning  
Double wall construction - stainless steel cylinder with a cool-touch stain resistant thermoplastic exterior



Verriegelter Sicherheitsklapdeckel, öffnet auf Knopfdruck mit schmaler Ausgusstülle - zum einfachen, tropfenfreien Ausgießen  
Sturdy interlocking safety lid with wide-mouth aperture - easy to fill and clean



Ergonomisch geformter Kunststoff-Griff (bleibt angenehm kühl) mit beleuchtetem Ein-/Ausschalter  
Full grip safety handle with illuminated power switch



MODERN. RELAXATION.

## TEA-X-PRESS

Schlicht, modern und funktional. TEA-X-PRESS ist der perfekte Wasserkocher für das Gästezimmer. Mit einer extra kleinen Füllmenge von 0,8 l ist er energieeffizient und Wasserverschwendung wird vorgebeugt. Sein geradliniges Design passt außerdem perfekt in reduzierte Interior Designs.

Simple, modern and functional. TEA-X-PRESS is the perfect kettle for the guest room. With an extra small capacity of 0.8 l, it is energy efficient and prevents water wastage. Its straightforward design also fits perfectly into minimalist interior designs.

0,8 Liter Füllmenge  
 Integriertes Heizelement  
 Kabellos, 360° drehbar  
 Doppelwandiges Gehäuse:  
 - innen: Edelstahl  
 - außen: wärmeisolierender Kunststoff  
 Deckel mit Sicherheitsverriegelung  
 Abschaltautomatik  
 Erweiterter Trockengehenschutz  
 Kontrollleuchte  
 STRIX Einheit  
 Füllstandsanzeige mit LED-Licht  
 Schutzklasse I

0.8 litre capacity  
 Integrated heating element  
 Cordless, 360° rotation  
 Double wall construction:  
 - inside: stainless steel  
 - outside: insulated cool touch housing  
 Lid with safety interlock  
 Automatic shut-off  
 Boil dry protection  
 Indicator light  
 STRIX unit  
 Water gauge with LED light  
 Class I

# 170300

schwarz matt  
 black matt

220-240 V, 50/60 Hz 1000-1200 W

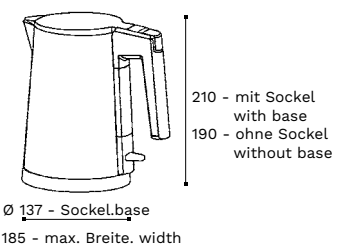

STRIX  
 safety controls



0,8 l



seamless interior



1000-1200 W



220-240 V



170300



ELEGANT. RETRO.

## EMPIRE

Der EMPIRE Wasserkocher vereint erlesenes Design mit bestechender Funktionalität, indem er energiesparende Technologien in einem stilvollen Retro-Design verpackt. Er beeindruckt mit einer 0,8 Liter Füllmenge, ideal für das schnelle Erhitzen kleinerer Wassermengen, ohne unnötigen Platz zu verschwenden.

The EMPIRE kettle combines exquisite design with impressive functionality by combining energy-saving technologies in a stylish retro design. It impresses with a 0.8 liter capacity, ideal for quickly heating small amounts of water without wasting unnecessary space.

0,8 Liter Füllmenge  
Integriertes Heizelement  
Kabellos, 360° drehbar  
Abschaltautomatik  
STRIX Einheit  
Erweiterter Trockengeherschutz  
Kontrollleuchte  
Deckel mit Verriegelung  
Edelstahlgehäuse  
Schutzklasse I

0.8 litre capacity  
Integrated heating element  
Cordless, 360° rotation  
Automatic shut-off  
STRIX unit  
Boil dry protection  
Indicator light  
Lid with safety interlock  
Stainless steel housing  
Class I

220-240 V, 50/60 Hz 1000-1200 W



# 170167

chrom/schwarz  
chrome/black

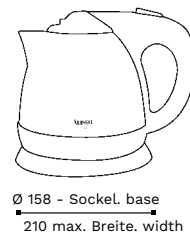

170 - mit Sockel  
with base  
150 - ohne Sockel  
without base

Ø 158 - Sockel. base  
210 max. Breite. width



STRIX  
safety controls



0,8 l



1000-1200 W



220-240 V



170167



TINY. GIANT.

## MINI

Klein in seinen Maßen, groß im Hotelzimmer. ALISEOs MINI bietet vollen Komfort auch für kleine Räume. Alle nötigen Sicherheitsfeatures inbegriffen. Dank Edelstahlgehäuse besonders langlebig und leicht zu reinigen.

Small in size, big in the hotel room. ALISEO's MINI offers full comfort even for small rooms. All the necessary safety features included. Particularly durable and easy to clean thanks to the stainless steel housing.

0,5 Liter Füllmenge  
 Integriertes Heizelement  
 Kabellos, 360° drehbar  
 Abschaltautomatik  
 STRIX Einheit  
 Erweiterter Trockengehschutz  
 Kontrollleuchte  
 Deckel mit Sicherheitsverriegelung  
 Edelstahlgehäuse  
 Schutzklasse I

0.5 litre capacity  
 Integrated heating element  
 Cordless, 360° rotation  
 Automatic shut-off  
 STRIX unit  
 Boil dry protection  
 Indicator light  
 Lid with safety interlock  
 Stainless steel housing  
 Class I

# 170211

chrom gebürstet/schwarz  
 brushed chrome/black

220-240 V, 50/60 Hz 1000 W

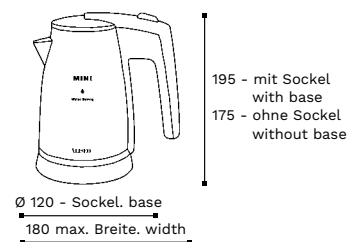

STRIX  
 safety controls



0,5 l



1000 W



220-240 V



170211



KERAMIKTASSE. CERAMIC MUG  
 H 100 mm, Ø 85 mm  
 2 x 250 ml  
 schwarz/weiß.  
 H 100 mm, Ø 85 mm  
 2 x 250 ml  
 black/white



HOLZTABLETT. BRIDGE TRAY  
 Hochwertiges, robustes Bambusholz  
 Schubfach aus langlebigem Melamin  
 260 x 44 x 160 mm  
 mahagoni/matt schwarz  
 High-quality, robust bamboo wood  
 Drawer made of durable melamine  
 260 x 44 x 160 mm  
 mahogany/matt black



MINI  
 Wasserkocher mit Wasserspa-  
 rendem 0,5 L Design  
 siehe Seite 94  
 Water kettle with 0,5 liter wa-  
 ter saving design  
 see page 94

3  
 IN ONE

SET.

## SPACE OASIS

Der SPACE OASIS vereint Wasser- und Energiesparfunktionen auf minimaler Fläche. Das platzsparende Set besteht aus einem hochwertigen, robusten Holztablett mit integrierter Schublade, unserem kompakten MINI Wasserkocher und zwei eleganten Keramiktassen. Perfekt für eine praktische und stilvolle Lösung auf kleinem Raum!

The SPACE OASIS combines water and energy-saving functions in a minimal space. The space-saving set consists of a high-quality, robust wooden tray with integrated drawer, our compact MINI kettle and two elegant ceramic cups. Perfect for a practical and stylish solution in a small space!

# 170259	Set
# 170254	Holztablett Bridge Tray
# 170258	Tasse Mug
# 170211	Wasserkocher MINI Water Kettle MINI



STRIX  
safety controls



0,5 l



1000 W



220-240 V



170259  
170254  
170258  
170211



**COURTESY TRAY**  
 Tablett 200 x 16 x 400 mm  
 Farbecht und kratzfest  
 Spülmaschinen geeignet  
 schwarz  
 Tray 200 x 16 x 400 mm  
 Colorfast and scratch resistant  
 Suitable for dishwashers  
 black



**PUZZLE**  
 Ablagebehälter 76 x 55 x 76 mm  
 Farbecht und kratzfest  
 Spülmaschinen geeignet  
 schwarz  
 Sachet box 76 x 55 x 76 mm  
 Colorfast and scratch resistant  
 Suitable for dishwashers  
 black



**PUZZLE**  
 Ablagebehälter 151 x 55 x 76 mm  
 Farbecht und kratzfest  
 Spülmaschinen geeignet  
 schwarz  
 Sachet box 151 x 55 x 76 mm  
 Colorfast and scratch resistant  
 Suitable for dishwashers  
 black



ALWAYS. FITS.

## COURTESY TRAY & PUZZLE

Ob einzeln genutzt oder clever kombiniert: Das schwarze COURTESY TRAY und die PUZZLE Ablagebehälter aus hochwertigem Melamin in edler Porzellanoptik passt sich jeder Situation im Hotelalltag an. Zwei Tablett lassen sich auch nahtlos aneinanderfügen und schaffen so mehr Platz für individuelle Arrangements.

Whether use individually or cleverly combined: The black COURTESY TRAY and PUZZLE sachet box made of high-quality melamine with a sophisticated porcelain look adapts to any situation in everyday hotel life. Two trays can also be joined together seamlessly to create more space for individual arrangements.

# 170277	COURTESY Tablett COURTESY Tray
# 170241	PUZZLE Ablagebehälter klein PUZZLE sachet box small
# 170240	PUZZLE Ablagebehälter groß PUZZLE sachet box tall



Kaffeemaschine, Wasserkocher BONJOUR, Tassen und Kapseln sind Dekoration  
 Coffee machine, water kettle BONJOUR, cups and capsules are decoration.



170277  
 170240  
 170241

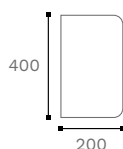



GRUNDTABLETT. BASE TRAY  
400 x 20 x 330 mm  
Farbecht und kratzfest  
Spülmaschinen geeignet  
schwarz  
400 x 20 x 330 mm  
Colorfast and scratch resistant  
Suitable for dishwashers  
black



SERVIERTABLETT. SERVING TRAY  
324 x 21 x 131 mm  
Farbecht und kratzfest  
Spülmaschinen geeignet  
schwarz  
324 x 21 x 131 mm  
Colorfast and scratch resistant  
Suitable for dishwashers  
black



PRODUKTABLAGE. SACHET TRAY  
130 x 40 x 100 mm  
Farbecht und kratzfest  
Spülmaschinen geeignet  
schwarz  
130 x 40 x 100 mm  
Colorfast and scratch resistant  
Suitable for dishwashers  
black

3  
IN ONE

SET.

## WELCOME TRAY SOLUTION

Das WELCOME TRAY ist mehr als ein Tablett – es ist ein durchdachtes System für stilvolle Gastlichkeit. Bestehend aus einem Grundtablett, einem kleineren Serviertablett und einer Produktablage lässt sich das Set aus hochwertigem Melamin in edler Porzellanoptik als WELCOME TRAY SOLUTION flexibel kombinieren oder einzeln verwenden.

The WELCOME TRAY is more than just a tray – it is a sophisticated system for stylish hospitality. Consisting of a basic tray, a smaller serving tray and a product tray, the set made of high-quality melamine with a sophisticated porcelain can be flexibly combined as WELCOME TRAY SOLUTION or used individually.

# 170229	Set
# 170226	Grundtablett Base tray
# 170227	Serviertablett Serving tray
# 170228	Produktablage Sachet tray



Wasserkocher EMPIRE # 170167 ist Dekoration.  
Water kettle EMPIRE # 170167 is decoration.



170229  
170226  
170227  
170228



CLEANED UP. WITH. STYLE.

## LUGGAGE RACKS

Ob funktional oder luxuriös – unsere Kofferablagen bieten für jedes Hotel die passende Lösung. Von praktischen Einsteigermodellen bis hin zu hochwertigen Premium-Ausführungen verbinden sie Design, Stabilität und Komfort. Besonders nachhaltig: Unsere Holz-Kofferablagen werden in Europa gefertigt und stammen aus zertifizierter, nachhaltiger Forstwirtschaft. Alle Modelle sind langlebig, robust und sorgen für eine komfortable Gepäckablage im Hotelzimmer.

Whether functional or luxurious - our luggage racks offer the right solution for every hotel. From practical entry-level models to high-quality premium versions, they combine design, stability and comfort. Particularly sustainable: our wooden luggage racks are manufactured in Europe and come from certified, sustainable forestry. All models are durable, robust and provide convenient luggage storage in the hotel room.

## KOFFERABLAGE

Mit Rückenlehne  
Beige Gurtbänder  
Klappbar  
Material: Edelstahl  
Oberfläche, verchromt

geklappt (B x H x T)  
67,5 x 89 x 9 cm

## LUGGAGE RACK

With back  
Beige straps  
Foldable  
Material: stainless steel  
Surface, chrome plated

folded (W x H x D)  
67,5 x 89 x 9 cm



# 080069

chrom  
chrome

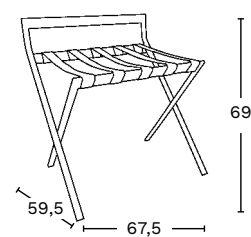

080069

# LUGGAGE RACKS

## KOFFERABLAGE

Mit Rückenlehne  
Schwarze Gurtbänder  
Klappbar  
Material: Stahlrohr

geklappt (B x H x T)  
68 x 85 x 10 cm

## LUGGAGE RACK

With back  
black straps  
Foldable  
Material: steel tube

folded (W x H x D)  
68 x 85 x 10 cm



# 080053	chrom chrome	mit Rückenlehne with back
# 080088	schwarz black	mit Rückenlehne with back

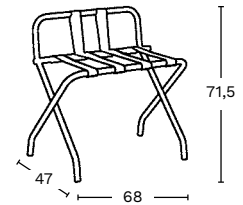

080053  
080088

## KOFFERABLAGE

Ohne Rückenlehne  
Schwarze Gurtbänder  
Klappbar  
Material: Stahlrohr

geklappt (B x H x T)  
68 x 65 x 9 cm

## LUGGAGE RACK

Without back  
black straps  
Foldable  
Material: steel tube

folded (W x H x D)  
68 x 65 x 9 cm

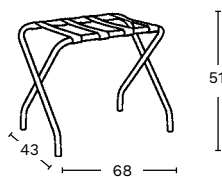

# 080055	chrom chrome	ohne Rückenlehne without back
# 080087	schwarz black	ohne Rückenlehne without back



080055  
080087

## KOFFERABLAGE

Mit Rückenlehne  
Schwarze Gurtbänder  
Klappbar  
Material: Holz, Buche

geklappt (B x H x T)  
60 x 77 x 10 cm

## LUGGAGE RACK

With back  
black straps  
Foldable  
Material: wood, beech

folded (W x H x D)  
60 x 77 x 10 cm

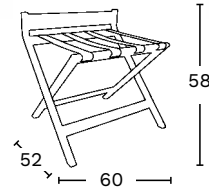

# 080047	natur natural	mit Rückenlehne with back
# 080086	schwarz gebeizt black stained	mit Rückenlehne with back
# 080049	mahagoni gebeizt mahogany stained	mit Rückenlehne with back



080047  
080086  
080049

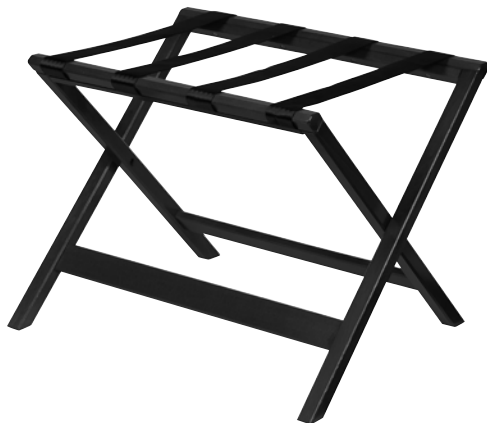

080043  
080089  
080045

## KOFFERABLAGE

Ohne Rückenlehne  
Schwarze Gurtbänder  
Klappbar  
Material: Holz, Buche

geklappt (B x H x T)  
60 x 65 x 7 cm

## LUGGAGE RACK

Without back  
black straps  
Foldable  
Material: wood, beech

folded (W x H x D)  
60 x 65 x 7 cm

# 080043	natur natural	ohne Rückenlehne without back
# 080089	schwarz gebeizt black stained	ohne Rückenlehne without back
# 080045	mahagoni gebeizt mahogany stained	ohne Rückenlehne without back

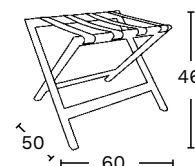



PFAS free

Unsere Bügeleisen sind mit einer hochwertigen Keramik-Bügelsohle ausgestattet – ganz ohne den Einsatz von PFAs (per- und polyfluorierte Alkylsubstanzen). Damit setzen wir seit jeher auf eine schadstofffreie Alternative, die sowohl für Ihre Gäste als auch für die Umwelt die bessere Wahl ist.

Our iron are equipped with a high-quality ceramic soleplate - without the use of PFAs (perfluorinated and polyfluorinated alkyl substances). This means we have always opted for a pollutant-free alternative that is better for both your guests and the environment.



2x Auto-shut-off

Alle unsere Bügeleisen verfügen über eine intelligente Abschaltautomatik:

In waagerechter Position schalten sie sich nach 30 Sekunden ohne Bewegung ab, in senkrechter Stellung nach 8 Minuten. Das schützt vor Brandgefahr und spart gleichzeitig Energie.

All our irons have an intelligent automatic switch-off function:

In the horizontal position, they switch off after 30 seconds without movement, in the vertical position after 8 minutes. This protects against the risk of fire and saves energy at the same time.



temperature limit

Unsere Bügeleisen sind auf eine maximale Temperatur von 200 °C begrenzt – deutlich niedriger als bei vielen Geräten im Privatbereich. So wird die Brandgefahr reduziert, ohne auf zuverlässige Glättung verzichten zu müssen.

Our irons are limited to a maximum temperature of 200°C – significantly lower than many appliances in the private sector. This reduces the risk of fire without compromising on reliable smoothing.



removable steam brush

Unser Dampfglätter besitzt einen abnehmbaren Bürstenkopf, der das steamen erleichtert - knitterfreie Kleidung im handumdrehen.

Our steamer has a removable brush that makes steaming easier - wrinkle-free clothes in no time.



self-cleaning function

Mit Hilfe der Selbstreinigungsfunktion unseres Dampfbügeleisen ist dieses langlebig und behält seine Leistungsfähigkeit - Rost und Kalk hat keine Chance.

With the help of our steam iron's self-cleaning function, it is durable and retains its performance - rust and limescale have no chance.



anti-drip

Das Anti-Tropf-System verhindert das Austreten von Wassertropfen aus unserem Dampfbügeleisen.

The anti-drip-system prevents water drops from escaping from our steam iron.



steam permeable mesh board

All unsere Bügelbretter werden mit einem dampfdurchlässigen, hitzebeständigen und gepolsterten Bezug geliefert.

All ironing boards come with a steam permeable, heat-resistant, and padded cover.



SAFETY. COMFORT. ENERGY EFFICIENCY.

## IRONING

Perfekte Kleidung im Handumdrehen – mit professionellen Bügellösungen für das Hotel. Vom leistungsstarken Bügeleisen über kompakte Steamer bis hin zu passenden Bügelbrettern gibt es alles für einen faltenfreien Auftritt. Besonders praktisch sind unsere Bügelstationen, die Bügeleisen und Bügelbrett kombinieren. In Kombination mit der speziell für Hotels entwickelten Bügeleisenhalterung, ist das Bügeleisen vor Diebstahl geschützt und ermöglicht eine sichere, platzsparende Aufbewahrung im Kleiderschrank. Hochwertig, langlebig und ideal für den täglichen Gästekomfort.

Perfect clothes in no time at all - with professional ironing solutions for the hotel. From powerful irons and compact steamers to matching ironing boards, we have everything you need for a wrinkle-free appearance. Our ironing stations, which combine an iron and ironing board, are particularly practical. In combination with the iron holder specially developed for hotels, the iron is protected against theft and enables safe, space-saving storage in the closet. High quality, durable and ideal for everyday guest comfort.



LITTLE. HELPER.

## STEAMO

Manchmal sind es die kleinen Dinge, die den Unterschied machen. STEAMO ist genau so ein Detail: ein kompakter Dampfglätter, der den Gästen das Leben erleichtert. Ob der Anzug für das Geschäftsmeeting oder das Kleid für den Abend – STEAMO entfernt mühelos Knitter und Falten, ganz ohne Bügelbrett. Und nebenbei bekommt die Kleidung einen dampfenden Frischekick.

Sometimes it's the little things that make the difference. STEAMO is just such a detail: a compact steamer that makes life easier for guests. Whether it's a suit for a business meeting or a dress for the evening - STEAMO effortlessly removes creases and folds, without the need for an ironing board. And the clothes also get a steaming freshness boost.

Dampfglätter  
 Inklusive Tasche zur Aufbewahrung  
 2 Dampfstufen  
 Dampfleistung 13-20 g/min  
 Wassertank 140 ml  
 Abnehmbarer Bürstenkopf  
 Hitzegeschütztes Anschlusskabel  
 Kabellänge: 190 cm

230 V, 50/60 Hz, 1000 W



Steamer  
 Including bag for storage  
 2 different steam levels  
 Steam output 13-20 g/min  
 Water tank 140 ml  
 Removable steam brush  
 Heat protected connection cable  
 Cord length: 190 cm

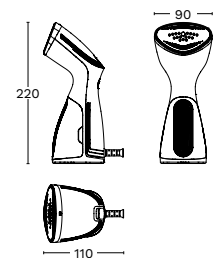

2 steam levels



removable  
steam brush



160250

# 160250    schwarz  
                  black



Dank seiner handlichen Größe findet STEAMO auch in kleinen Schubladen problemlos Platz und kommt in einer praktischen Aufbewahrungstasche. So ist er immer griffbereit, wenn es schnell gehen muss.

Thanks to its handy size, STEAMO also fits easily into small drawers and comes in a useful storage bag. So it's always ready to hand when you need it quickly.





HOT. BLACK. STYLISH.

## ONYX

Das Dampfbügeleisen ONYX kombiniert kraftvolle Leistung und Effizienz mit elegantem Design. Die starke Dampffunktion glättet Textilien mühelos, während die automatische Abschaltung im Stehen und Liegen für maximale Sicherheit sorgt. Perfekt für stilbewusste Hotelzimmer, in denen Funktionalität und Ästhetik gleichermaßen zählen.

The ONYX steam iron combines powerful performance and efficiency with elegant design. The powerful steam function smoothes textiles effortlessly, while the automatic switch-off function ensures maximum safety when standing or lying down. Perfect for style-conscious hotel rooms where functionality and aesthetics are equally important.

Dampfbügeleisen  
 2-fach automatische Sicherheitsabschaltung  
 - horizontal nach 30 Sekunden  
 - vertikal nach 8 Minuten  
 Antihaftbeschichtete Keramik-Bügelsohle  
 Anti-Kalk-System  
 Anti-Tropf-System  
 Selbstreinigungssystem  
 Hitzegeschütztes Anschlusskabel  
 Kabellänge 190 cm  
 Schutzklasse I

Steam iron  
 Double safety automatic shut-off  
 -horizontal after 30 seconds  
 -vertical after 8 minutes  
 Non-stick ceramic soleplate  
 Anti-calc-system  
 Anti-drip-system  
 Self-cleaning system  
 Heat protected connection cable  
 Cord length 190 cm  
 Class I

220-240 V, 50/60 Hz, 2000-2400 W

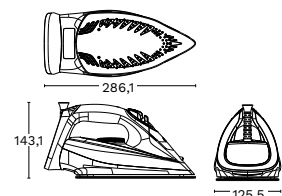

steam iron



2x Auto-shut-off



self-cleaning  
function



anti-drip



PFAS free



temperature  
limit



160230



# 160230	schwarz black
----------	------------------



- 1 Antihftbeschichtete, PFAs-freie Keramik-Bügelsohle  
Non-stick, PFAs free ceramic soleplate
- 2 Dampffunktion wahlweise mit komprimiertem Dampf- oder Wasserspray  
Steam function optionally with compressed steam or water spray
- 3 Mehrstufige Temperaturregelung für verschiedenste Textilien und Materialien  
Rotating Fabric Control Dial for different textiles



CONVENIENT. SAFE. EFFICIENT.

## SAHARA

Das SAHARA Bügeleisen kombiniert moderne Technik mit praktischer Funktionalität. Es verfügt über eine doppelte automatische Abschaltung für mehr Sicherheit, eine antihaftbeschichtete Keramiksohle für leichtes Bügeln und ein hitzebeständiges Kabel für volle Bewegungsfreiheit. Damit ist das Bügeln bequem, sicher und effizient.

The SAHARA iron combines modern technology with practical functionality. It has a double automatic switch-off for greater safety, a non-stick ceramic soleplate for easy ironing and a heat-resistant cable for complete freedom of movement. This makes ironing convenient, safe and efficient.

Trockenbügelleisen

2-fach automatische Sicherheitsabschaltung

- horizontal nach 30 Sekunden

- vertikal nach 8 Minuten

Antihaftbeschichtete Keramik-Bügelsohle

Hitzegeschütztes Anschlusskabel

Kabellänge 240 cm

Schutzklasse I

220-240 V, 50/60 Hz, 900-1100 W



Dry iron

Double safety automatic shut-off

- horizontal after 30 seconds/

- vertical after 8 minutes

Non-stick ceramic soleplate

Heat protected connection cable

Cord length 240 cm

Class I

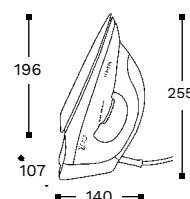

dry iron



2x Auto-shut-off



PFAS free



temperature  
limit



160172

ECO  
SMART  
Energy Saving  
1100 W

# 160172

silber/champagne  
silver/champagne



- 1 Anti-Haft-Beschichtung  
E-Z glide non-stick coating
- 2 2-fach automatische Abschaltung  
Double safety automatic shut-off
- 3 Ergonomischer Antirutsch-Griff ermöglicht  
bequemes Bügeln  
Ergonomic anti-slip handle for comfortable  
ironing

FITS. IN.

## HANG-UP

# 160130

Bügeleisenaufhängung  
für Trockenbügelleisen Sahara  
schwarz

Hitzebeständige Rückwand  
Montage mit oder ohne Haken für Bügelbrett  
Hang-up organizer  
for dry iron Sahara  
black

Heat resistant back plate  
Mounted with or without  
board hanger

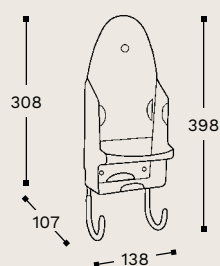

# IRON HOLDER

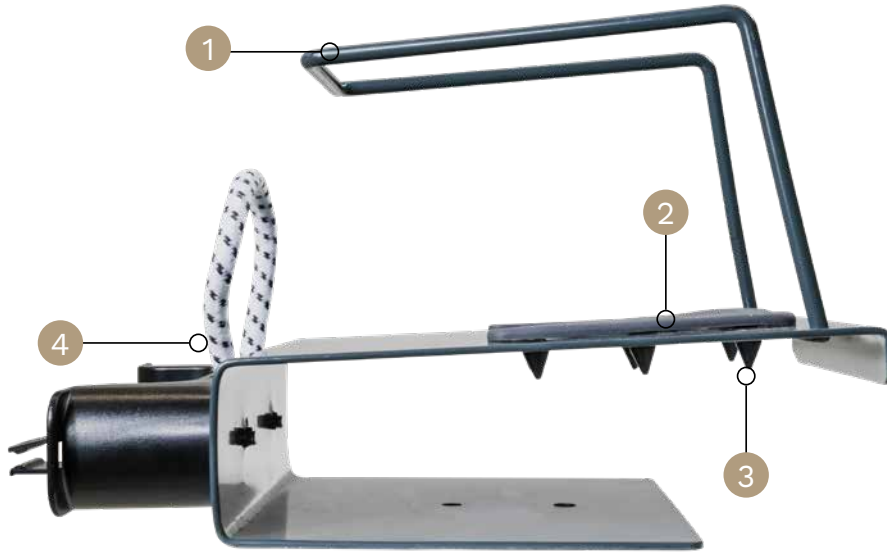

- 1 Passend für Trockenbügelleisen SAHARA und Dampfbügelleisen ONYX  
Accommodates both SAHARA dry Iron and ONYX steam iron
- 2 Bügelleisen liegt geschützt in der Halterung auf rutschfesten, hitzebeständigen Silikonpads  
Iron rests securely in place on heat resistant non-slip silicone pads
- 3 Austauschbare Silikonpads sind fixiert durch überstehende Noppen  
Replaceable pads are fastened to the holder via soft-pointed silicone inserts
- 4 Diebstahlsicher - Bügelleisenkabel wird durch die Halterung fest mit Bügelbrett verbunden  
Theft protection – cable secured through the holder/board

## SICHERHEITSHALTER FÜR BÜGELEISEN

Passend zu Trockenbügelleisen SAHARA und Dampfbügelleisen ONYX  
Zur Montage an Bügelbretter MI-PRO, MINI-MAX, MINI-MEEE  
237 x 140 x 150 mm (B x H x T)

## SAFETY IRON HOLDER

Suitable for dry iron SAHARA und steam iron ONYX  
For mounting on ironing boards MI-PRO, MINI-MAX, MINI-MEEE  
237 x 140 x 150 mm (W x H x D)

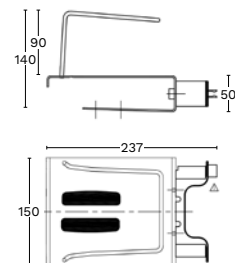

# 160233

dunkelgrau/schwarz  
dark grey/black



steam iron



dry iron



160233



- 1 Doppelrohrkonstruktion aus Stahlrohr mit Pulverbeschichtung in dunkelgrau  
Double leg construction made of steel tube with powder coating in dark grey
- 2 Stabiler rutschfester Gummifuß  
Stable non-skid rubber footing
- 3 Höhenverstellbar 67-73-79-85 cm mit hitzebeständigem und gepolsterem Bezug in grau  
Height adjustment 67-73-79-85 cm with heat resistant and padded cover in grey
- 4 Bügeleisen ist in hängender Position an seinem Platz gesichert + klappbarer Aufhängehaken  
Irons are secured safely in place for board storage in hanging position + fold away suspension hook
- 5 Elektroanschluss mit Netzkabel 180 cm  
Schuko extension cord 180 cm

# 160200

MI-PRO SAHARA

Bügelbrett mit Sicherheitshalterung  
und Trockenbügeleisen  
Ironing board with safety holder  
and dry iron

# 160239

MI-PRO ONYX

Bügelbrett mit Sicherheitshalterung  
und Dampfbügeleisen  
Ironing board with safety holder  
and steam iron

# 160212

MI-PRO

Bügelbrett ohne Sicherheitshalterung  
Ironing board without safety holder

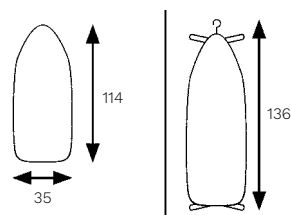

Set	Weight
Bügelbrett. Board MI-PRO	4,3 kg
Elektroanschluss. Schuko extension cord	0,3 kg
Halterung. Iron holder	1,0 kg
Bügeleisen. Iron SAHARA	0,8 kg
Bügeleisen. Iron ONYX	1,1 kg
<b>Total</b>	<b>6,4/ 6,7 kg</b>



steam permeable  
mesh board



160200  
160239  
160212

# MINI-MAX



Für SAHARA & ONYX  
 For SAHARA & ONYX

- 1 MINIMUM PROFILE. MAXIMUM BOARD SPACE.  
Speziell entwickelt für die Aufbewahrung in kleinen Schränken  
Specifically engineered for small cabinet storage
- 2 Stabiles Gestell aus Stahlrohr mit Pulverbeschichtung in dunkelgrau mit rutschfestem Gummifuß  
Sturdy frame made of steel tube with powder coating in dark grey with non-skid rubber footing
- 3 Höhenverstellbar 60-63-66-69-72-75-78 cm mit hitzebeständigem und gepolsterem Bezug in grau  
Height adjustment 60-63-66-69-72-75-78 cm with heat resistant and padded cover in grey
- 4 Bügeleisen ist in hängender Position an seinem Platz gesichert + klappbarer Aufhängehaken  
Irons are secured safely in place for board storage in hanging position + fold away suspension hook
- 5 Elektroanschluss mit Netzkabel 180 cm  
Schuko extension cord 180 cm

# 160219  
 MINI-MAX SAHARA  
 Bügelbrett mit Sicherheitshalterung  
 und Trockenbügelleisen  
 Ironing board with safety holder  
 and dry iron

# 160242  
 MINI-MAX ONYX  
 Bügelbrett mit Sicherheitshalterung  
 und Dampfbügelleisen  
 Ironing board with safety holder  
 and steam iron

# 160225  
 MINI-MAX  
 Bügelbrett ohne Sicherheitshalterung  
 Ironing board without safety holder

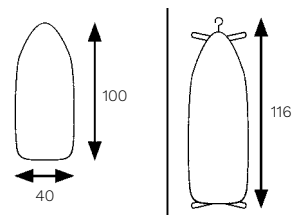

Set	Weight
Bügelbrett. Board MINI-MAX	4,4 kg
Elektroanschluss. Schuko extension cord	0,3 kg
Halterung. Iron holder	1,0 kg
Bügeleisen. Iron SAHARA	0,8 kg
Bügeleisen. Iron ONYX	1,1 kg
<b>Total</b>	<b>6,5/ 6,8 kg</b>





- 1 Zusammenklappbar für den Tisch mit klappbarem Aufhängehaken  
Double leg construction made of steel tube with powder coating in dark grey
- 2 Hitzebeständiger und gepolsterter Bezug in grau  
Heat resistant and padded cover in grey
- 3 Stabiles Gestell mit Transportsicherung aus Stahlrohr mit Pulverbeschichtung in dunkelgrau  
Sturdy frame with transport safety lock made of steel tube with powder coating in dark grey

# 160194

MINI-MEEE SAHARA

Tischbügeltisch mit Sicherheitshalterung  
und Trockenbügelleisen

Table top ironing board with safety holder  
and dry iron

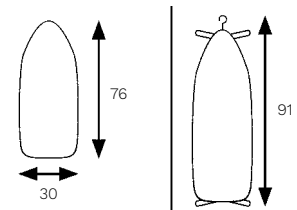

# 160245

MINI-MEEE ONYX

Tischbügeltisch mit Sicherheitshalterung  
und Dampfbügelleisen

Table top ironing board with safety holder  
and steam iron

# 160188

MINI-MEEE

Tischbügeltisch ohne Sicherheitshalterung

Table top ironing board without safety holder

Set	Weight
Bügeltisch. Board MINI-MEEE	1,9 kg
Halterung. Iron holder	1,0 kg
Bügelleisen. Iron SAHARA	0,8 kg
Bügelleisen. Iron ONYX	1,1 kg
Total	3,7/ 4,0 kg



steam permeable  
mesh board



#  
160194  
160245  
160188

# E-ZEE CONCEPT



Für SAHARA & ONYX  
 For SAHARA & ONYX

- 1 Hitzebeständige Eisenablage  
Heat Resistant Iron Rest
- 2 Klappbarer Aufhängehaken  
Fold-away suspension hook
- 3 Elektroanschluss mit Netzkabel 180 cm  
Integrated Schuko extension cord 180 cm
- 4 Höhenverstellbar 70-77-84-89 cm mit hitzebeständigem und gepolstertem Bezug in grau  
Height adjustment 70-77-84-89 cm with heat resistant and padded cover in grey
- 5 Stabiles Gestell mit Transportsicherung aus Stahlrohr mit Pulverbeschichtung in chrom mit rutschfestem Gummifuß  
Sturdy frame with transport safety lock made of steel tube with powder coating in chrome with non-skid rubber footing

# 160175  
 E-ZEE SAHARA  
 Bügelbrett mit Trockenbügelleisen  
 Ironing board with dry iron

# 160236  
 E-ZEE ONYX  
 Bügelbrett mit Dampfbügelleisen  
 Ironing board with steam iron

# 160111  
 E-ZEE  
 Bügelbrett  
 Ironing board

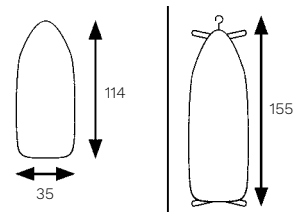

Set	Weight
Bügelbrett. Board E-ZEE	4,3 kg
Elektroanschluss. Schuko extension cord	0,3 kg
Bügelleisen. Iron SAHARA	0,8 kg
Bügelleisen. Iron ONYX	1,1 kg
<b>Total</b>	<b>5,4/ 5,7 kg</b>

  
 steam permeable  
 mesh board

#  
 160175  
 160236  
 160111



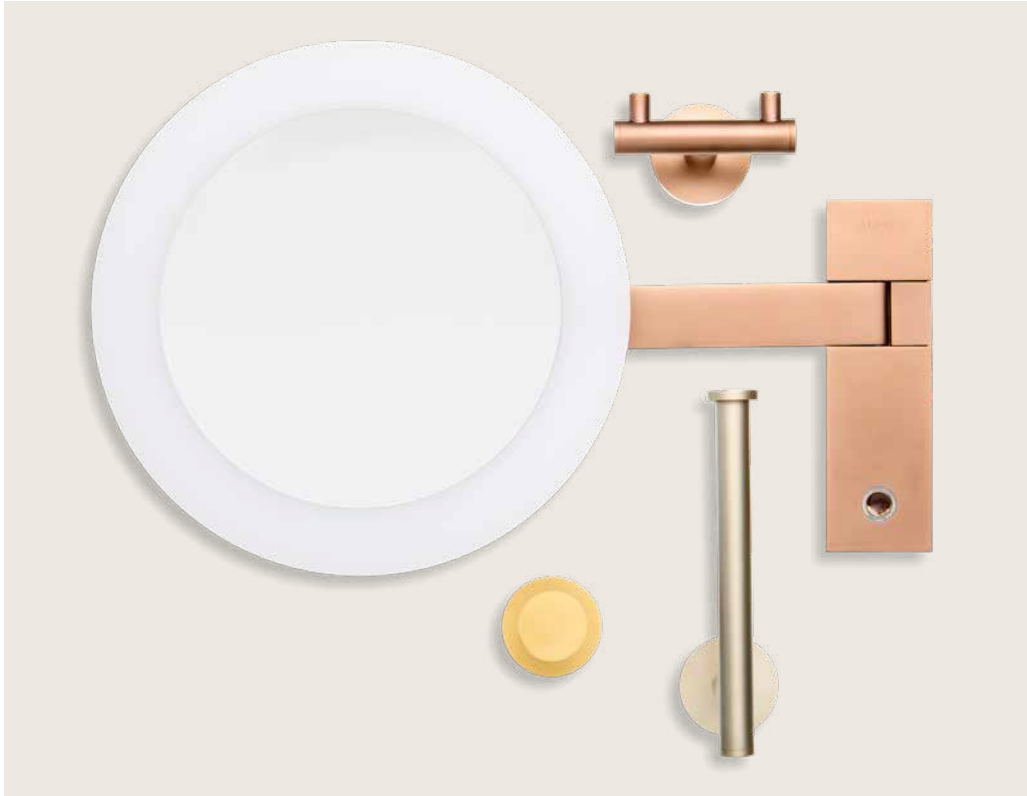

# ALISEO

ALISEO GmbH • Leutkirchstraße 63 • 77723 Gengenbach • Germany  
+49 (0) 7803 60279-0  
info@aliseo.de  
www.aliseo.de