

2026

KOSMETIKSPIEGEL
COSMETIC MIRRORS

ALISEO



NU finishes

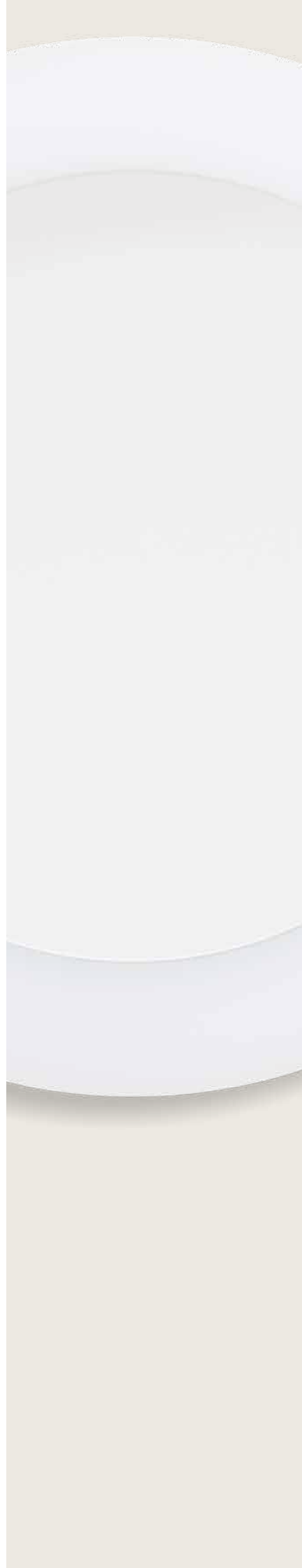

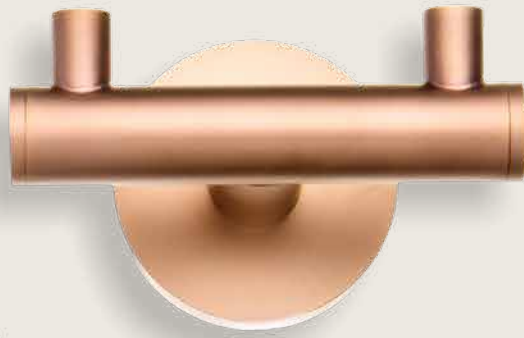

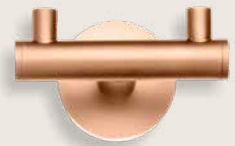

AM ANFANG STEHT DIE VISION IT ALL STARTS WITH A VISION



Individuelle Farben und Oberflächen ermöglichen die perfekte Umsetzung Ihrer Vision. Denn es sind Details wie diese, die den Unterschied machen. Wir haben mit ALISEO ATELIER einen Bereich geschaffen, in dem wir grenzenlose Farbvielfalt ermöglichen.

Stöbern Sie im ATELIER Katalog oder entdecken Sie noch mehr Inspiration online.

Individual colors and surfaces enable the perfect implementation of your vision. Because it's details like these that make the difference. With ALISEO ATELIER, we have created an area in which we enable limitless color variety.

Have a look through the ATELIER catalog or discover even more inspiration online.

GRENZENLOSE FARBAUSWAHL UNLIMITED CHOICE OF COLORS

Der Kreativität sind keine Grenzen gesetzt: Im PVD-Verfahren lassen sich nahezu alle Farben realisieren. Als Basis genügt ein Muster oder der Farbcode des Herstellers. Zur Vereinfachung haben wir die beliebtesten metallischen Farben – jeweils poliert oder gebürstet – übersichtlich zusammengestellt und uns dabei an gängigen Oberflächen namhafter Sanitärhersteller orientiert. Perfect Match eben.

There are no limits to creativity: Nearly any color can be achieved with the PVD process. A sample or the manufacturer's color code is all we need. To make things easier, we have compiled the most popular metallic colors—each available in polished or brushed finishes—in a clear overview, taking inspiration from the common surface tones of renowned sanitary manufacturers. A perfect match.

POLIERT. POLISHED

CHROM 100
CHROME 100



CHROM 302
CHROME 302

BRONZE 201



BRONZE 301

GOLDOPTIK 203
GOLD OPTIC 203



GOLDOPTIK 303
GOLD OPTIC 303

MESSING 206
BRASS 206



MESSING 306
BRASS 306

NICKEL 207



NICKEL307

ROTGOLD 209
RED GOLD 209



ROTGOLD 309
RED GOLD 309

CHROM SCHWARZ 211
BLACK CHROME 211



CHROM SCHWARZ 311
BLACK CHROME 311

GEBÜRSTET. BRUSHED



Alle Artikel, bei denen das Symbol der NU finishes zu finden ist, kann mit Wunschoberfläche gestaltet werden.

All items with the NU finishes symbol can be designed with the individual finish of your choice.



Unsere Oberflächen in Sonderfarbe entstehen durch PVD-Beschichtung. Egal ob Hochglanz, gebürstet oder matt, die Vorteile sind klar: Sie ist langlebig, kratzfest und trotz Feuchtigkeit. Und weil wir von der Qualität überzeugt sind, gewähren wir eine freiwillige Garantie von 5 Jahren. Bitte beachten Sie unsere Montage- und Pflegehinweise.

Our surfaces in special colors are created by PVD coating. Whether high polish, brushed or matt, the advantages are clear: it is durable, scratch-resistant and withstands moisture. And because we are convinced of the quality, we offer a voluntary 5-year guarantee. Please note our installation and care instructions.



Die T3-Technologie macht Lichtsteuerung intuitiv: Ein Touch genügt, um zwischen warmweißem Licht, kaltweißem Licht und Aus zu wechseln. So lässt sich die Beleuchtung individuell anpassen – je nach Tageszeit, Umgebung oder Vorliebe. Ein komfortables Extra, das Gästen spürbar mehr Kontrolle und Wohlbefinden schenkt. (Standardausführung bei den Kosmetikspiegeln SATURN, CUBIK und MOON DANCE.)

Revolutionary T³ lighting makes light control intuitive: one touch is all it takes to switch between warm white light, cool white light and off. This allows the lighting to be individually adjusted - depending on the time of day, surroundings or preference. A convenient extra that gives guests noticeably more control and well-being. (Standard on SATURN, CUBIK and MOON DANCE mirrors.)



magnification

Unsere Kosmetikspiegel mit 3-fach-Vergrößerung bieten die perfekte Balance zwischen Übersicht und Genauigkeit und sorgen für ein komfortables, natürliches Spiegelbild. Dank dieser Vergrößerungsstufe behalten Sie das gesamte Gesicht im Blick – für ein rundum angenehmes Nutzungserlebnis.

Our cosmetic mirrors with 3x magnification offer the perfect balance between overview and accuracy, ensuring a comfortable, natural reflection. Thanks to this magnification level, you can see your entire face at a glance – for an all-round pleasant user experience.



magnification

Unsere Kosmetikspiegel mit 5-fach-Vergrößerung ermöglichen eine besonders detailgenaue Ansicht – selbst feinste Nuancen werden sichtbar. In Kombination mit unseren hochwertigen Spiegelflächen bietet die 5-fach-Vergrößerung ein luxuriöses Pflegeerlebnis – für Perfektion, die man sieht.

Our cosmetic mirrors with 5x magnification provide a particularly detailed view—even the finest nuances become visible. In combination with our high-quality mirror surfaces, the 5x magnification offers a luxurious skincare experience—for perfection you can see.



green efficiency

Unsere Kosmetikspiegel mit wartungsfreier LED-Beleuchtung kombinieren Energieeffizienz mit langer Lebensdauer. Die LEDs sind einzeln geschaltet – fällt mal eine aus, leuchten die anderen zuverlässig weiter. Und das Beste: Die Beleuchtung ist als Ersatzteil erhältlich und einfach austauschbar. Für nachhaltigen Komfort und dauerhaft strahlende Gästerlebnisse.

Our vanity mirrors with maintenance-free LED lighting combine energy efficiency with a long service life. The LEDs are individually switched - if one fails, the others continue to light up reliably. And best of all, the lighting is available as a spare part and is easy to replace. For lasting comfort and a long-lasting, radiant guest experience.



ambient light

Spiegel mit transluzenter Rückseite erzeugen ein sanftes, indirektes Licht – perfekt für eine elegante Ambientebeleuchtung. Das Licht fällt nicht nur nach vorn, sondern auch dezent nach hinten und taucht den Raum in eine stimmungsvolle Atmosphäre. Ein stilvolles Extra, das jedes Bad aufwertet.

Mirrors with translucent backs create a soft, indirect light - perfect for elegant ambient lighting. The light not only falls to the front, but also discreetly to the rear, bathing the room in an atmospheric ambience. A stylish extra that enhances any bathroom.



NU finishes

Mit den NU finishes gestalten Sie alle Kosmetikspiegel und Badaccessoires in Ihrer Wunschoberfläche und -farbe. Wir setzen diese dann als hochwertige PVD-Beschichtung um. Brillant, langlebig, kratz- und korrosionsbeständig und einfach zu reinigen.

With NU finishes, you can customize all cosmetic mirrors and bathroom accessories in the surface and color of your choice. We then apply these as a high-quality PVD coating. Brilliant, durable, scratch and corrosion-resistant and easy to clean.



PERFECT. DESIGN.

LED MOON DANCE





PERFECT. DESIGN.

LED MOON DANCE

Die faszinierende Schönheit des Mondes am Nachthimmel war Inspiration für das aktuelle Flaggschiff der ALISEO Kosmetikspiegel. In der Zusammenarbeit mit SIEGER DESIGN als eines der renommiertesten Design Studios in Deutschland entstand nicht nur eine perfekte Formensprache, sondern auch technische Perfektion. Die mondartige Aura des Spiegels entsteht durch den nahtlosen transluzenten Acrylkörper, der sein Licht auf subtile Weise ganzheitlich in alle Richtungen entfaltet.

The fascinating beauty of the moon in the night sky was inspiration for the ALISEO's current flagship cosmetic mirror. In collaboration with SIEGER DESIGN, one of the most renowned design studios in Germany, not only a perfect design language was created, but also technical perfection. The mirror's moon-like aura is created by the seamless translucent acrylic body, which subtly unfolds its light holistically in all directions.

product concept + design: sieger design

SMD-LED-Beleuchtung
Warmweißes Licht, 3500-4000 K
Kühles weißes Licht, 5000-5500 K
T3-Technologie: zwei wählbare Lichttöne
3-fach-Vergrößerung
Beleuchteter Tastschalter
Transluzenter Acryl-Rahmen
Schutzklasse I
100-240 V
Direktanschluss
Messingkonstruktion

SMD-LED-lighting
Warm white light, 3500-4000 K
Cool white light, 5000-5500 K
T3-Technology: two switchable light tones
3x magnification
Lighted touch switch
Translucent acrylic frame
Class I
100-240 V
Hard wire application
Brass construction

CE CB  IP44

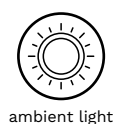

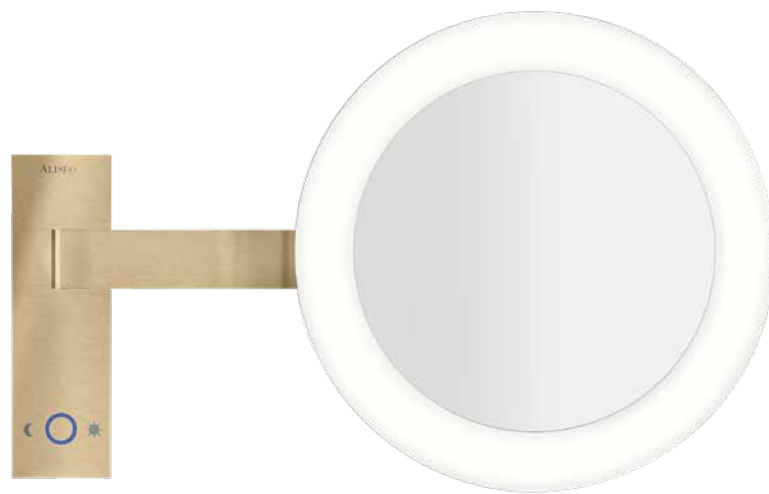

Bronze 301
bronze 301

020758

chrom Schwenkarm ø 240 mm
chrome single arm ø 240 mm

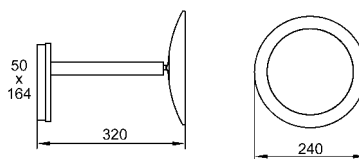

020758



LED MOON DANCE



# 020759	chrom	Standmodell	ø 240 mm
	chrome	free standing	ø 240 mm

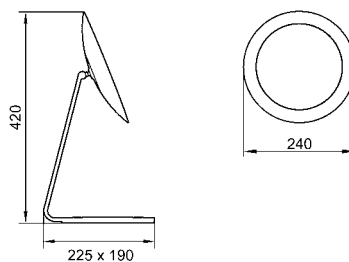

020759





JUST. FEEL. GOOD.

LED ME





JUST. FEEL. GOOD.

LED ME

Preis/Leistung wird groß geschrieben beim LED ME. Durch optimierte Prozesse und ein schlichtes Design gibt es trotzdem keine Einschränkungen in Sachen Qualität. Die supersparsame LED-Beleuchtung macht nicht nur ein schönes warmes Licht, sondern liefert auch genug Helligkeit durch den transluzenten Acrylrahmen, für eine stimmungsvolle Ambientebeleuchtung.

Price/performance is a top priority with the LED ME. Thanks to optimized processes and a simple design, there are no compromises in terms of quality. The super economical LED lighting not only creates a beautiful warm light, but also provides enough brightness through the translucent acrylic frame for atmospheric ambient lighting.

Acryl-Hintergrundbeleuchtung
SMD-LED-Beleuchtung
Warmweißes Licht, 3500-4000 K
3-fach-Vergrößerung
Kugelgelenk
Schutzklasse I
100-240 V
Direktanschluss

Acrylic backlight design
SMD-LED-lighting
Warm white light, 3500-4000 K
3x magnification
Full pivotal adjustment
Class I
100-240 V
Hard wire application

CE CB 



green efficiency



ambient light



NU finishes



magnification



chrom schwarz 211
black chrome 211

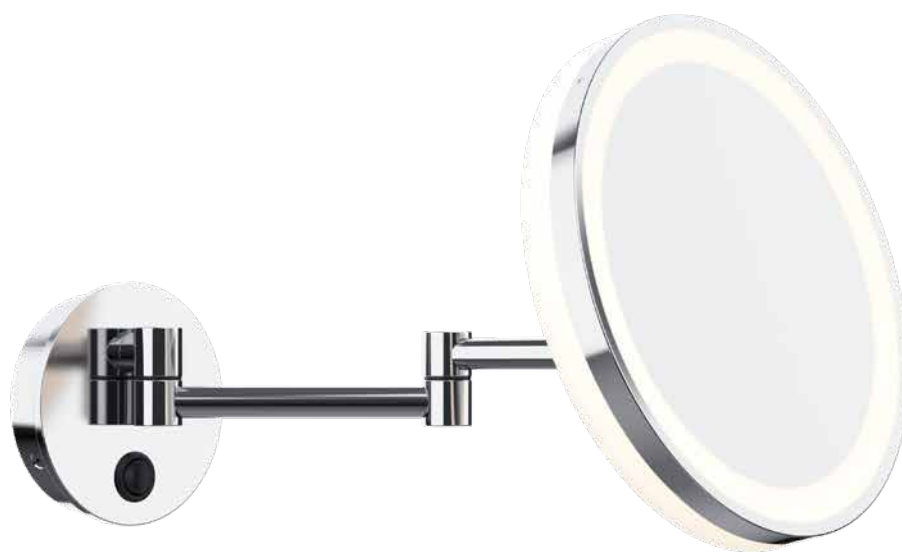

# 020835	chrom chrome	Schwenkarm single arm	ø 220 mm ø 220 mm
----------	-----------------	--------------------------	----------------------

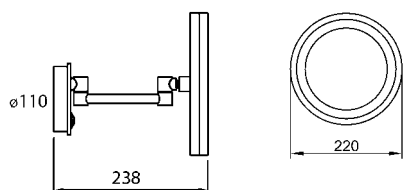

020835

# 020836	chrom chrome	Doppel-Schwenkarm double arm	ø 220 mm ø 220 mm
----------	-----------------	---------------------------------	----------------------

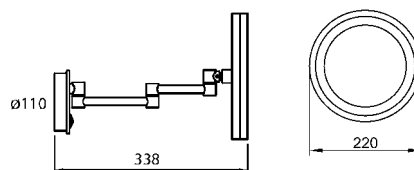

020836



FOR. EVERYONE.

LED MY

Ein Spiegel für jeden! Mit seinem zeitlosen, schlichten Design ohne Schnickschnack ist der MY Spiegel die perfekte Wahl für alle, die einen eleganten, minimalistischen und funktionalen Look lieben. Eine smarte, budgetfreundliche Option!

A mirror for everyone! With its timeless, simple, no-frills design, the MY mirror is the perfect choice for anyone who loves an elegant, minimalist and functional look. A smart, budget-friendly option!

SMD-LED-Beleuchtung
Warmweißes Licht, 3500-4000 K
3-fach-Vergrößerung
Doppelwalzengelenk
Schutzklasse I
100-240 V
Direktanschluss

SMD-LED-lighting
Warm white light, 3500-4000 K
3x magnification
Full pivotal adjustment
Class I
100-240 V
Hard wire application



green efficiency



NU finishes



magnification



Bronze 301
bronze 301



NEW

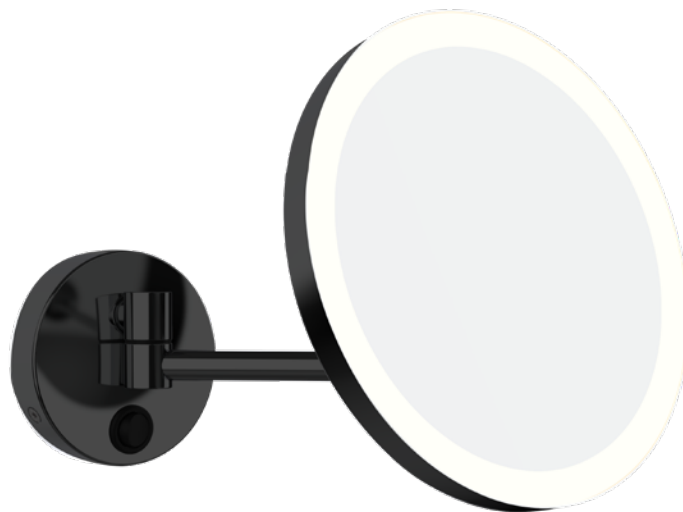

schwarz matt
black matt

# 020843	chrom	Schwenkarm	ø 220 mm
	chrome	single arm	ø 220 mm
# 020843.102	schwarz matt	Schwenkarm	ø 220 mm
	black matt	single arm	ø 220 mm

# 020844	chrom	Doppel-Schwenkarm	ø 220 mm
	chrome	double arm	ø 220 mm
# 020844.102	schwarz matt	Doppel-Schwenkarm	ø 220 mm
	black matt	double arm	ø 220 mm

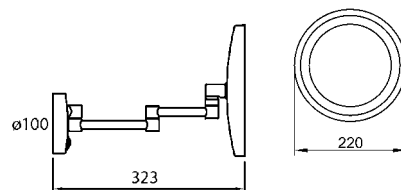
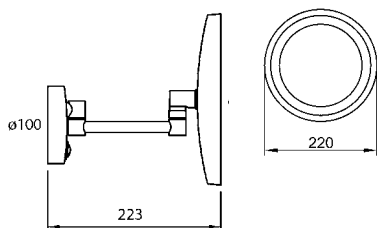

020843



020843.102



020844



020844.102

LED SATURN



Nickel 207
nickel 207



# 020743	chrom chrome	Schwenkarm single arm	ø 220 mm ø 220 mm
----------	-----------------	--------------------------	----------------------

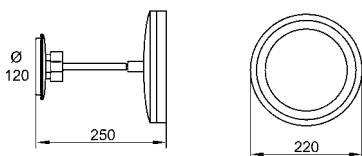

020743

# 020744	chrom chrome	Doppel-Schwenkarm double arm	ø 220 mm ø 220 mm
----------	-----------------	---------------------------------	----------------------

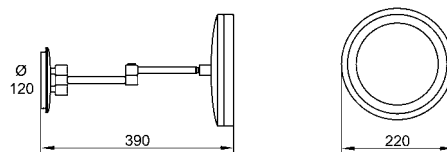

020744



ALL-ENCOMPARRING. CLASSIC. LUXUS.

LED SATURN

Der beleuchtete Kosmetikspiegel für anspruchsvolle Nutzende. LED SATURN. Dank unserer exklusiven Two-Tone-Touch-Technologie wechselt die Lichtfarbe mit einer Berührung zwischen kalt- und warmweiß. Möglich wird das durch zwei unabhängige LED-Systeme im Inneren des Spiegels. Und weil wir auch bei diesen unsichtbaren Komponenten nur die besten verbauen, ist LED SATURN super sparsam und mit einer wartungsfreien Laufzeit bis zu 50.000 Stunden.

The illuminated cosmetic mirror for discerning users. LED SATURN. Thanks to our exclusive Two-Tone-Touch technology, the light color changes between cold and warm white with a single touch. This is possible by two independent LED systems inside the mirror. And because we also use only the best components even if it comes to the invisible ones, LED SATURN is super economical and has a maintenance-free life span of up to 50,000 hours.

SMD-LED-Beleuchtung
 Warmweißes Licht, 3500-4000 K
 Kühles weißes Licht, 5000-5500 K
 T3-Technologie: zwei wählbare Lichttöne
 3-fach-Vergrößerung
 Beleuchteter Tastschalter
 Kugelgelenk
 Schutzklasse I
 100-240 V
 Direktanschluss
 Messingkonstruktion

SMD-LED-lighting
 Warm white light, 3500-4000 K
 Cool white light, 5000-5500 K
 T3-Technology: two switchable light tones
 3x magnification
 Lighted touch switch
 Full pivotal adjustment
 Class I
 100-240 V
 Hard wire application
 Brass construction





Nickel gebürstet 307
brushed nickel 307



Messing 206
brass 206





Chrom 100
chrome 100

CONTEMPORARY. INDEPENDENT.
LED INTERFACE





NEW

CONTEMPORARY. INDEPENDENT.

LED INTERFACE

LED INTERFACE vereint alle Anforderungen der heutigen Zeit. Dank seines Infrarotsensors leuchtet das Licht nur, wenn der Spiegel in Benutzung ist. Zusammen mit der besten LED-Technologie ist er dadurch ultrasparsam. So ist es möglich diesen beleuchteten Kosmetikspiegel wahlweise mit Batterien oder Akkus zu betreiben.

LED INTERFACE combines all of today's requirements. Thanks to its infrared sensor, the light is only switched on when the mirror is in use. Together with the best LED technology, this makes it ultra-economical. It is therefore possible to operate this illuminated cosmetic mirror on battery power. A power connection is not necessary.

SMD-LED-Beleuchtung

Warmweißes Licht, 3500-4000 K

3-fach-Vergrößerung

Batteriebetrieben 4 x 18650 Akkubatterien

USB-Aufladung

Ein-/Ausschaltung durch Infrarotsensor

Messing-Komponenten

Schwenk-/Kippgelenk (Schwenkarm)

Kippgelenk (Standspiegel)

Adapterplatte für bessere Stabilität

SMD-LED-lighting

Warm white light, 3500-4000 K

3x magnification

Battery powered 4 x 18650 rechargeable batteries

USB charging

Switched on/off by infrared sensor

Brass components

Full pivotal adjustment

Adapter plate for improved stability

CE



battery powered



sensor



automatic switch-off



green efficiency



NU finishes



magnification

USB
charging



Automatisches Einschalten durch Gesichtsannäherung. Ein Infrarot-Sensor aktiviert die automatische Ein-/Ausschaltung der LED-Beleuchtung im transluzenten Acrylrings im Abstand von 20 cm.
Lights automatically as your face approaches. Auto ON/OFF infrared sensor activates a translucent acrylic edge LED lighting system. Operational up to 20 cm.

020859 chrom Schwenkarm ø 220 mm
chrome single arm ø 220 mm

020858 chrom Standmodell ø 220 mm
chrome free standing ø 220 mm

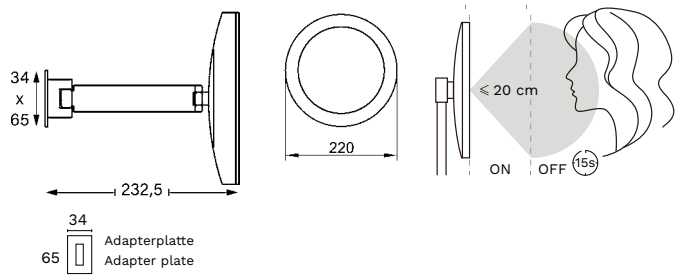

020859

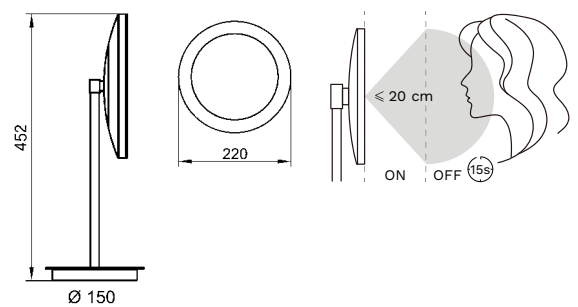

020858



schwarz matt
black matt

STYLE. AND. FUNCTION. LED CITY LIGHT

Der LED CITY LIGHT setzt neue Maßstäbe in Stil und Funktion. Mit einem Durchmesser von 250 mm bietet er ausreichend Fläche für eine komfortable und umfassende Nutzung. Sein modernes Design, erhältlich in einer eleganten schwarz-matten Pulverbeschichtung oder einem glänzenden Chrom-Finish, verleiht ihm einen zeitgemäßen und stilvollen Look.

The LED CITY LIGHT sets new standards in style and function. With a diameter of 250 mm, it offers sufficient surface area for comfortable and comprehensive use. Its modern design, available in an elegant black matt powder coating or a shiny chrome finish, gives it a contemporary and stylish look.

SMD-LED-Beleuchtung
Warmweißes Licht, 3500-4000 K
3-fach-Vergrößerung
Doppelwalzengelenk
Schutzklasse I
100-240 V
Direktanschluss

SMD-LED-lighting
Warm white light, 3500-4000 K
3x magnification
Full pivotal adjustment
Class I
100-240 V
Hard wire application



green efficiency



NU finishes



magnification



schwarz matt
black matt



020677 chrom Schwenkarm ø 250 mm
chrome single arm ø 250 mm

020657 chrom Doppel-Schwenkarm ø 250 mm
chrome double arm ø 250 mm

020801 schwarz matt Doppel-Schwenkarm ø 250 mm
black matt double arm ø 250 mm

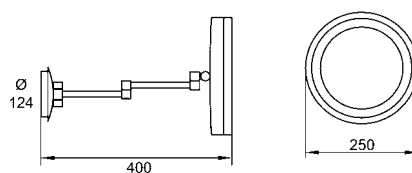
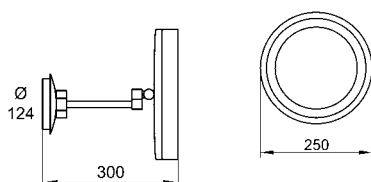

020677



020657



020801

MIRA

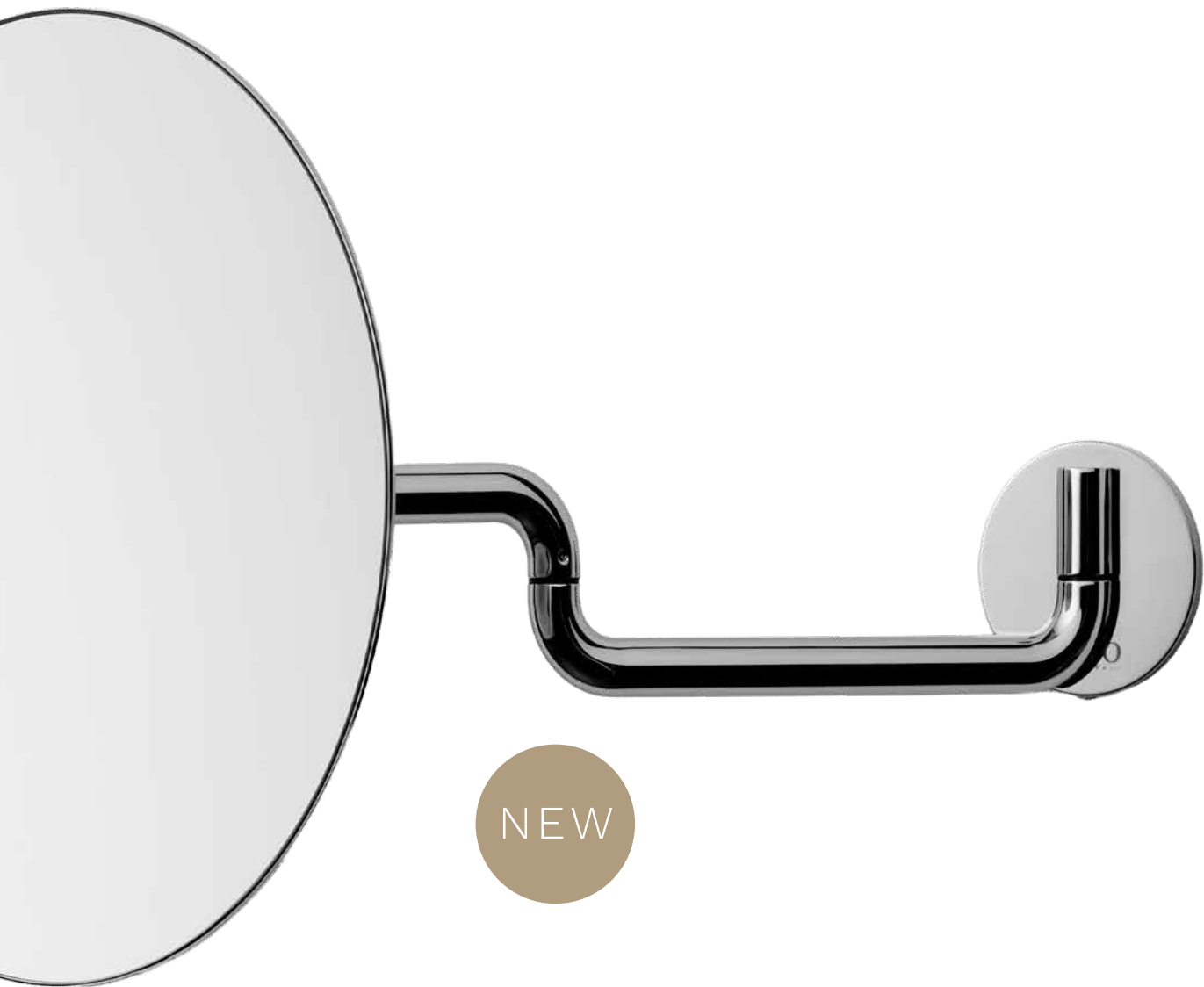

HARMONY. PURE. ELEGANCE.

MIRA

Der Spiegel MIRA zeigt, wie schön reine Schlichtheit sein kann. Ohne Beleuchtung konzentriert er sich auf das Wesentliche und strahlt gerade dadurch eine ruhige, zeitlose Eleganz aus. Der geformte Arm verleiht dem Design eine harmonische, weiche Linie und sorgt zugleich für angenehme Bedienbarkeit.

The mirror MIRA shows how beautiful pure simplicity can be. Without lighting, it focuses on the essentials and thus radiates a calm, timeless elegance. The shaped arm gives the design a harmonious, soft line and at the same time ensures pleasant usability.

5-fach-Vergrößerung
Kugelgelenk
Verdeckte Montageeinheit

5x magnification
Full pivotal adjustment
Covered backplate





# 020867	chrom	Schwenkarm	ø 200 mm
	chrome	single arm	ø 200 mm

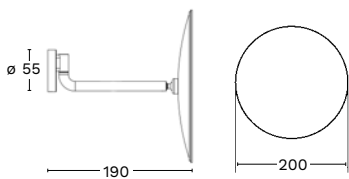

020867

# 020868	chrom	Doppel-Schwenkarm	ø 200 mm
	chrome	double arm	ø 200 mm

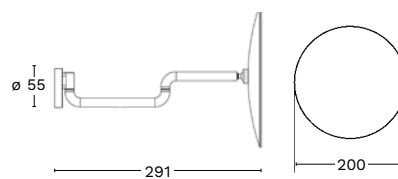

020868



CLASSIC. MINIMALIST.

COSMO MINIMALIST

COSMO MINIMALIST ist so wunderbar schlicht, wie ein Kosmetikspiegel nur sein kann. Ohne Beleuchtung ist er auf das absolut Wesentliche reduziert und macht damit eine gute Figur. Beste Materialien machen ihn in jeder Hinsicht zu einem Begleiter für die Ewigkeit.

COSMO MINIMALIST is as wonderfully simple as a cosmetic mirror can be. Without lighting, it is reduced to the absolute essentials and cuts a fine figure. The best materials make it a companion for eternity in every respect.

3-fach-Vergrößerung
Schwenk-/Kippgelenk
Verdeckte Montageeinheit

3x magnification
Full pivotal adjustment
Covered backplate





schwarz matt
black matt

# 020488	chrom chrome	Standmodell free standing	Ø 200 mm Ø 200 mm
# 020805	schwarz matt black matt	Standmodell free standing	Ø 200 mm Ø 200 mm

# 020607	chrom chrome	Schwenkarm single arm	Ø 200 mm Ø 200 mm
# 020804	schwarz matt black matt	Schwenkarm single arm	Ø 200 mm Ø 200 mm

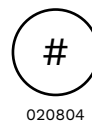
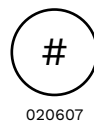
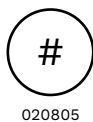
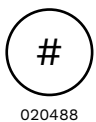
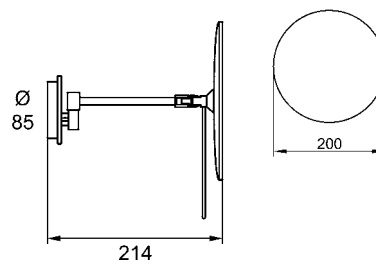
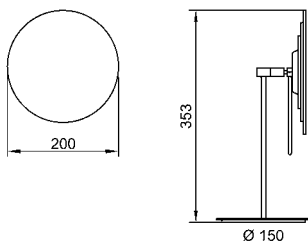

JUST. FEEL. GOOD.

FACE





goldoptik 203
gold optic 203

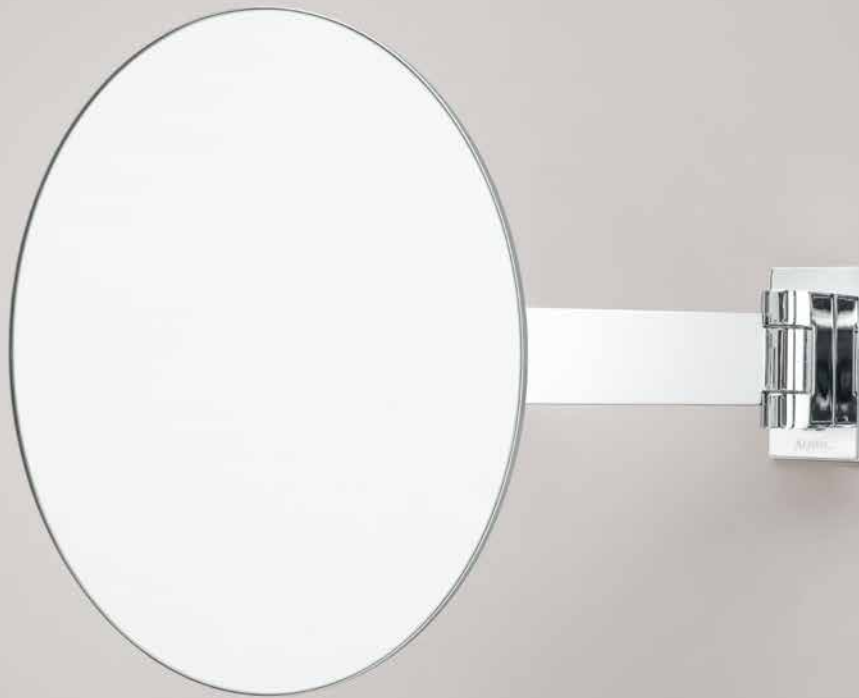

JUST. FEEL. GOOD.

FACE

FACE vereint randlose Eleganz mit einer cleveren Klapptechnik. Durch sie lässt er sich ultraflach an die Wand klappen und ist an feiner Ästhetik kaum zu übertreffen. Auf eine Beleuchtung haben wir bewusst verzichtet und so ist ein Elektroanschluss nicht nötig. Weniger ist auch hier wieder mehr.

FACE combines frameless elegance with clever folding technology. It can be folded ultra-flat against the wall and is hard to beat in terms of fine aesthetics. We have deliberately avoided using lighting, so there is no need for an electrical connection. Once again, less is more.

3-fach-Vergrößerung
 5-fach-Vergrößerung (Standmodell)
 Schwenk-/Kippgelenk
 Kugelgelenk (Standmodell)
 Verdeckte Montageeinheit
 Adapterplatte für bessere Stabilität

3x magnification
 5x magnification (free standing)
 Full pivotal adjustment
 Covered backplate
 With adapter plate for more stability



magnification



magnification

NEW

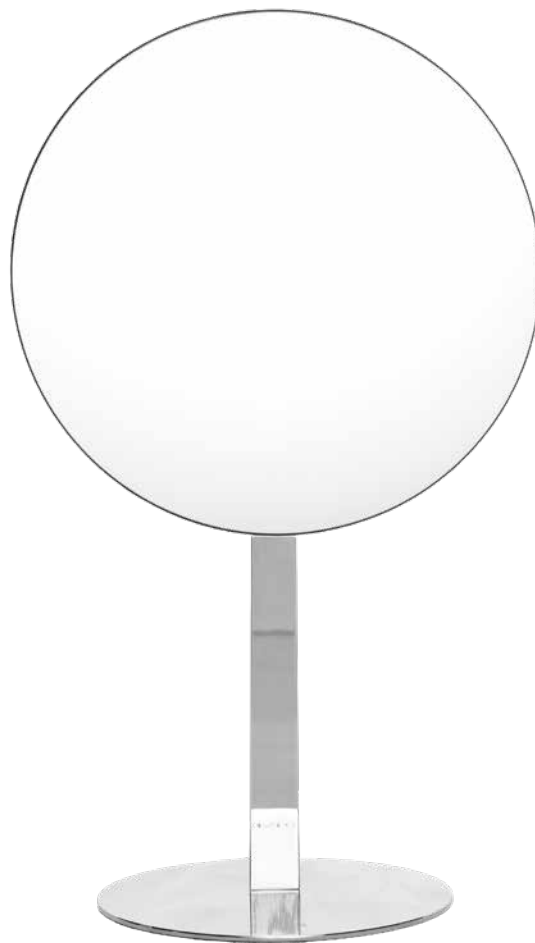

020866 chrom Standmodell ø 200 mm
chrome free standing ø 200 mm

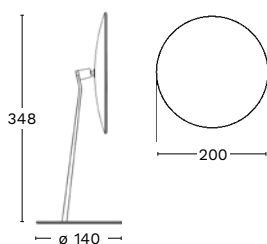

020831 chrom Schwenkarm ø 200 mm
chrome single arm ø 200 mm

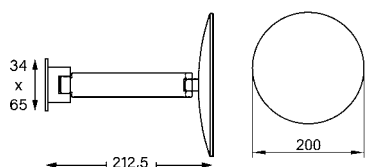

34
65
Adapterplatte
Adapter plate



020831

020829 chrom Doppel-Schwenkarm ø 200 mm
chrome double arm ø 200 mm

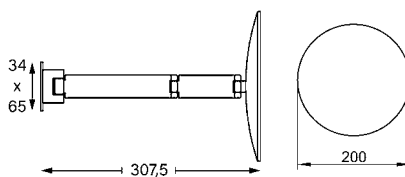

34
65
Adapterplatte
Adapter plate



020829



020866



schwarz matt
black matt

SIMPLE. FUNCTIONAL. DURABLE.

CONCIERGE COLLECTION

Unsere Spiegel überzeugen durch hochwertige Verarbeitung, präzise Vergrößerung und zeitloses Design. Sie sind langlebig, pflegeleicht und ideal für den täglichen Einsatz im Hotelbad. Dank verschiedener Farben und Ausführungen fügen sie sich flexibel in jedes Interieur ein und bieten Gästen eine komfortable, detaillierte Spiegelansicht.

Our mirrors stand out with their high-quality workmanship, precise magnification, and timeless design. They are durable, easy to maintain, and ideal for daily use in hotel bathrooms. Available in various colours and finishes, they adapt flexibly to any interior and provide guests with a comfortable, detailed reflection.

Planspiegel und 3-fach-Vergrößerung

Verdeckte Montageeinheit

Messing-Komponenten

Drehgelenk

Plain mirror an 3x magnification

Covered backplate

Brass components

Full pivotal adjustment

# 020802	schwarz matt black matt	Doppel-Schwenkarm double arm	∅ 200 mm ∅ 200 mm
----------	----------------------------	---------------------------------	----------------------

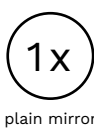
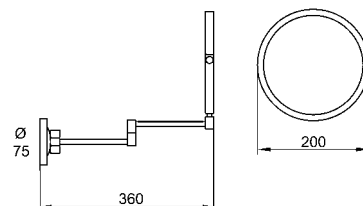

plain mirror



magnification

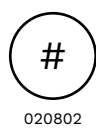

020802



DOPPELSPIEGEL – FLEXIBEL UND KOMFORTABEL

Ob Detailarbeit oder Gesamtbild: Eine Seite vergrößert 3-fach, die andere zeigt das natürliche Spiegelbild. Einfach wenden – praktisch, intuitiv, perfekt für jeden Gast.

DOUBLE-SIDED MIRROR – FLEXIBLE & CONVENIENT

For precision or the perfect overview: one side offers 3x magnification, the other shows a natural reflection. Simply flip – practical, intuitive, ideal for every guest.

Planspiegel und 3-fach-Vergrößerung

Verdeckte Montageeinheit

Messing-Komponenten

Drehgelenk

Plain mirror and 3x magnification

Covered backplate

Brass components

Full pivotal adjustment

020506

chrom	Schwenkarm	∅ 200 mm
chrome	single arm	∅ 200 mm

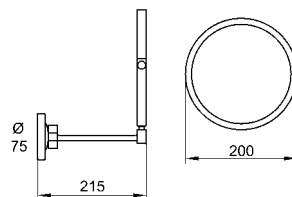

plain mirror



magnification



020506

NEW

PERFECT. DESIGN.

BATHROOM MIRRORS







NEW

ROUND. BRUSHED. STYLISH.

ORE

Der runde Spiegel ORE bringt moderne Eleganz in das Badezimmer. Sein filigraner, goldfarbener Rahmen aus gebürstetem Aluminium setzt hochwertige Akzente und verleiht dem Spiegel eine edle und zeitlose Ausstrahlung. Ob als stilvoller Mittelpunkt über dem Waschtisch oder als dekoratives Highlight an einer freien Wand – dieser Spiegel bringt Harmonie und Leichtigkeit in jeden Raum.

The round mirror ORE brings modern elegance to the bathroom. Its delicate, gold-colored frame made of brushed aluminum adds high-quality accents and gives the mirror a sophisticated and timeless look. Whether as a stylish focal point above the washbasin or as a decorative highlight on a free wall, this mirror brings harmony and lightness to any room.

# 020874	gold gebürstet	ø 600 mm
	brushed gold	ø 600 mm

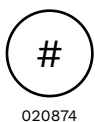
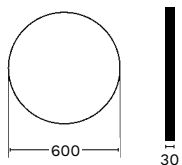

020874

# 020875	gold gebürstet	ø 800 mm
	brushed gold	ø 800 mm

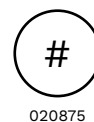
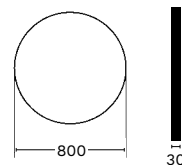

020875



NEW

OVAL. BRUSHED. STYLISH.

JOY

Der ovale Spiegel JOY setzt stilvolle Akzente in deinem Badezimmer. Der feine goldene Rahmen aus gebürstetem Aluminium verleiht dem Spiegel einen modernen und edlen Look und sorgt für eine hochwertige Optik. Ob vertikal oder horizontal aufgehängt – dieser dekorative Spiegel passt sich perfekt jedem Raumkonzept an und bringt Eleganz und Funktionalität in Einklang.

The oval mirror JOY adds stylish accents to your bathroom. The delicate golden frame made of brushed aluminum gives the mirror a modern, elegant look and ensures a high-quality appearance. Whether hung vertically or horizontally, this decorative mirror fits perfectly into all room concept and harmonizes elegance and functionality.

# 020876	gold gebürstet	400 x 800 mm
	brushed gold	400 x 800 mm

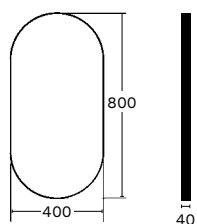

020876

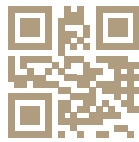
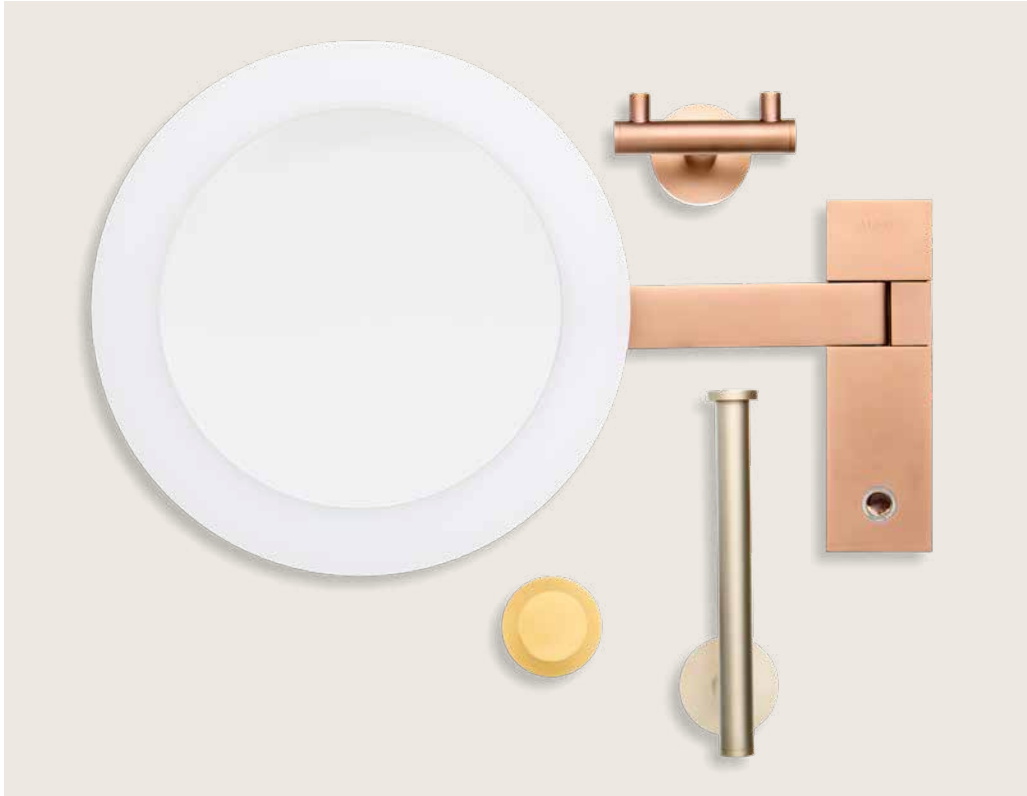

ALISEO

ALISEO GmbH • Leutkirchstraße 63 • 77723 Gengenbach • Germany
+49 (0) 7803 60279-0
info@aliseo.de
www.aliseo.de